

(Provisional)

MYANMAR

NATIONAL

BUILDING

CODE

2012

PART 5D

BUILDING SERVICES

(WATER SUPPLY, DRAINAGE AND SANITATION)

PART 5D PLUMBING SERVICES

TABLE OF CONTENTS

NO.	TITLE	PAGE
5D.1	SCOPE	1
5D.2	TERMINOLOGY	1
5D.3	GENERAL	15
5D.4	WATER SUPPLY	19
5D.5	DRAINAGE AND SANITATION	57
5D.6	SOLID WASTE MANAGEMENT	110

PLUMBING SERVICES**SECTION 1 WATER SUPPLY, DRAINAGE AND SANITATION
(INCLUDING SOLID WASTE MANAGEMENT)****5D.1 SCOPE****5D.1.1**

This Section covers the basic requirements of water supply for residential, business and other types of buildings, including traffic terminal stations. This Section also deals with general requirements of plumbing connected to public water supply and design of water supply systems.

5D.1.1.1

This Section does not take into consideration the requirements of water supply for industrial plants and processes, which have to be provided for separately. It also does not provide the requirements of water supply for other purposes, such as fire fighting, and street cleaning.

5D.1.2

This Section also covers the design, layout, construction and maintenance of drains for foul water, surface water and subsoil water and sewage; together with all ancillary works, such as connections, manholes and inspection chambers used within the building and from building to the connection to a public sewer, private sewer, individual sewage-disposal system, cesspool, soak away or to other approved point of disposal/ treatment work.

NOTE — A sanitary drainage system consists of a building sewer, a building drain, a soil and/or waste stack, horizontal branches or fixture drain, and vents. The sanitary drainage of a large building may have a number of primary and secondary branches, and several soil and/or waste stacks, each of them in turn may have a number of horizontal branches.

5D.2 TERMINOLOGY**5D.2.1.1 Access Panel**

Removable panel mounted in a frame, normally secured with screws and mounted in a wall or ceiling, to provide access to concealed appurtenances or items which may require maintenance.

5D.2.1.2 Air Gap —

The distance between the lowest point of a water inlet or feed pipe to an appliance and the spill-over level (or the overflowing level) of the appliance.

5D.2.1.3 Air Valve —

A valve that releases air from a pipeline automatically without loss of water, or introduce air into a line automatically if the internal pressure becomes less than that of the atmosphere.

5D.2.1.4 Authority Having Jurisdiction —

The Authority which has been created by a statute and which for the purpose of administering the Code/Part may authorize a committee or an official to act on its behalf; hereinafter called the 'Authority'.

5D.2.1.5 Available Head —

The head of water available at the point of consideration due to mains' pressure or overhead tank or any other source of pressure.

5D.2.1.6 Back Siphonage —

The flowing back of used, contaminated, or polluted water from a plumbing fixture or vessel into a water supply due to a reduced pressure in such pipe (see Backflow).

5D.2.1.7 Back Up —

A condition where the wastewater may flow back into another fixture or compartment but not back into the potable water system.

5D.2.1.8 Backflow

- a) The flow of water or other liquids, mixtures or substances into the distributing pipes of a system of supply of potable water from any source or sources other than its intended source.
- b) The flow of a liquid in a direction reverse of that intended.

5D.2.1.9 Backflow Prevention Device —

Any approved measure or fitting or combination of fittings specifically designed to prevent backflow or back-siphonage in a water service.

5D.2.1.10 Barrel —

This portion of a pipe in which the diameter and wall thickness remain uniform throughout.

5D.2.1.11 Base —

The lowest portion or lowest point of a stack of vertical pipe.

5D.2.1.12 Battery of Fixtures —

Any group of two or more similar adjacent fixtures which discharge into a common horizontal waste or soil pipe.

5D.2.1.13 Bedding —

The material on which the pipe is laid and which provides support for the pipe. Bedding can be concrete, granular material or the prepared trench bottom.

5D.2.1.14 Benching —

Slopping surfaces constructed on either side of channels at the base of a manhole or inspection chamber for the purpose of confining the flow of sewage, avoiding the accumulation of deposits and providing a safe working platform.

5D.2.1.15 Branch

- a) Special form of sewer pipe used for making connections to a sewer or water main. The various types are called 'T', 'Y', 'T-Y' double Y and V branches, according to their respective shapes.
- b) Any part of a piping system other than a main or stack.

5D.2.1.16 Branch Soil Pipe (BSP) —

A pipe connecting one or more soil appliances to the main soil pipe.

5D.2.1.17 Branch Soil Waste Pipe (BSWP) —

A pipe connecting one or more soil and/or waste appliances to the main soil waste pipe (one pipe system).

5D.2.1.18 Branch Ventilating Pipe (BVP) —

A pipe, one end of which is connected to the system adjacent to the trap of an appliance and the other to a main ventilating pipe or a drain-ventilating pipe. It is fitted to prevent loss of water seal from a trap owing to partial vacuum, back-pressure, or surging caused by air movement within the pipe system. It also provides ventilation for the branch waste pipe.

5D.2.1.19 Branch Waste Pipe (BWP) —

A pipe connecting one or more waste appliances to the main waste pipe.

5D.2.1.20 Building Drain, Combined —

A building drain which conveys both sewage and storm water or other drainage.

5D.2.1.21 Building Drain, Sanitary —

A building drain which conveys sewage and sullage only.

5D.2.1.22 Building Drain, Storm —

A building drain which conveys storm water or other drainage but no sewage.

5D.2.1.23 Building Sewer —

That part of the horizontal piping of a drainage system which extends from the end of the building drain and which receives the discharge of the building drain and conveys it to a public sewer, private sewer, individual sewage- disposal system or approved point of disposal.

5D.2.1.24 Building Sub-Drain —

That portion of a drainage system which cannot drain by gravity in the building sewer.

5D.2.1.25 Building Trap —

A device, fitting or assembly of fittings installed in the building drain to prevent circulation of air between the drainage of the building and the building sewer. It is usually installed as running trap.

5D.2.1.26 Cesspool

- a) An underground chamber for the reception and storage of foul water, the contents of which are periodically removed for disposal.
- b) A box-shaped receiver constructed in a roof or gutter for collecting rainwater which then passes into a rainwater pipe connected thereto.

5D.2.1.27 Chair —

A bed of concrete or other suitable material on the trench floor to provide a support for the pipes at intervals.

5D.2.1.28 Channel —

The open waterway through which sewage, storm water or other liquid wastes flow at the invert of a manhole or an inspection chamber.

5D.2.1.29 Chute —

A vertical pipe system passing from floor to floor provided with ventilation and inlet openings for receiving refuse from successive floors and ending at the ground floor on the top of the collecting chambers.

5D.2.1.30 Cistern —

A fixed container for water in which water is at atmospheric pressure. The water is usually supplied through a float operated valve.

5D.2.1.31 Cleaning Eye —

An access opening in a pipe or pipe fitting arranged to facilitate the cleaning of obstructions and fitted with removable cover.

5D.2.1.32 Clear Waste Water —

Cooling water and condensate drainage from refrigeration and air conditioning equipment, cooled condensate from steam heating systems, cooled boiler blow-down water, waste water drainage from equipment rooms and other areas where water is used without an appreciable addition of oil, gasoline, solvent, acid, etc, and treated effluent in which impurities have been reduced below a minimum concentration considered harmful.

5D.2.1.33 Collection Chamber —

A compartment situated at the lower end of the chute for collecting and housing the refuse during the period between two successive cleanings.

5D.2.1.34 Communication Pipe —

That part of a service pipe which vests in the water undertakes. It starts at the water main and terminate at a point which differs according to the circumstances of the case.

5D.2.1.35 Connection —

The junction of a foul water drain, surface water drain or sewer from building or building with public sewer treatment works, public sewer, private sewer, individual sewage-disposal system, cess pool, soakaway or to other approved point of disposal/treatment work.

5D.2.1.36 Consumer —

Any person who uses or is supplied water or on whose application such water is supplied by the Authority.

5D.2.1.37 Consumer's Pipe —

The portion of service pipe used for supply of water and which is not the property of the Authority (*see* Fig. 1).

5D.2.1.38 Cover

- a) A removable plate for permitting access to a pipe, fitting, vessel or appliance.
- b) The vertical distance between the top of the barrel of a buried pipe or other construction and the surface of the ground.

5D.2.1.39 Cross-Connection —

A connection between two normally independent pipelines which permits flow from either pipeline into the other.

5D.2.1.40 Crown of Trap —

The topmost point of the inside of a trap outlet.

5D.2.1.41 Deep Manhole —

A manhole of such depth that an access shaft is required in addition to the working chamber.

5D.2.1.42 Depth of Manhole —

The vertical distance from the top of the manhole cover to the outgoing invert of the main drain channel.

5D.2.1.43 Diameter —

The nominal internal diameter of pipes and fittings.

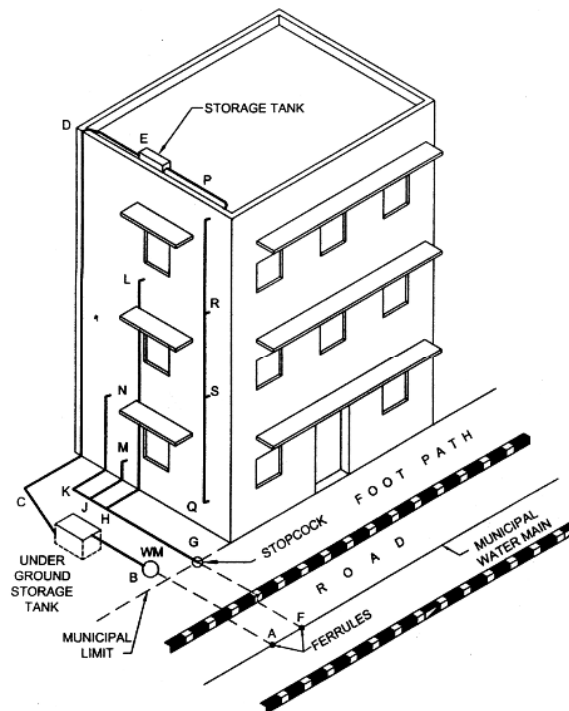

NOTE – The illustration is not intended to indicate recommended positions of underground storage tank (where provided), pipes, etc and this will depend on local situations.

Figure 1 Typical Sketch For Identification Of Different Types Of Water Supply Pipes

5D.2.1.44 Direct Tap —

A tap which is connected to a supply pipe and is subject to pressure from the water main.

5D.2.1.45 Downtake Tap —

A tap connected to a system of piping not subject to water pressure from the water main.

5D.2.1.46 Drain —

A conduit, channel or pipe for the carriage of storm water, sewage, waste water or other water-borne wastes in a building drainage system.

5D.2.1.47 Drain Ventilating Pipe (DVP) —

A pipe installed to provide flow of air to or from a drain to prevent undue concentration of foul air in the drain. The main soil pipe or main waste pipe may serve as drain ventilating pipe wherever their upper portions, which do not receive discharges, are extended to the roof level and let open to air.

5D.2.1.48 Drainage —

The removal of any liquid by a system constructed for the purpose.

5D.2.1.49 Drainage Work—

The design and construction of a system of drainage.

5D.2.1.50 Drop Connection —

A length of conduit installed vertically immediately before its connection to a sewer or to another drain.

5D.2.1.51 Drop Manhole —

A manhole installed in a sewer where the elevation of the incoming sewer considerably exceeds that of the outgoing sewer; a vertical waterway outside the manhole is provided to divert the waste from the upper to the lower level so that it does not fall freely into the manhole except at peak rate of flow.

5D.2.1.52 Effective Opening —

The minimum cross-sectional area at the point of water supply, measured or expressed in terms of:

- a) the diameter of a circle; and
- b) the diameter of a circle of equivalent cross-sectional area, if the opening is not circular.

5D.2.1.53 Feed Cistern —

A storage vessel used for supplying cold water to a hot water apparatus, cylinder or tanks.

5D.2.1.54 Fittings —

Fittings shall mean coupling, flange, branch, bend, tees, elbows, unions, waste with plug, P or S trap with vent, stop ferrule, stop tap, bib tap, pillar tap, globe tap, ball valve, cistern storage tank, baths, water-closets, boiler, geyser, pumping set with motor and accessories, meter, hydrant, valve and any other article used in connection with water supply, drainage and sanitation.

5D.2.1.55 Fixture Unit —

A quantity in terms of which the load producing effects on the plumbing system of different kinds of plumbing fixtures is expressed on some arbitrarily chosen scale.

5D.2.1.56 Fixture Unit Drainage —

A measure of probable discharge into the drainage system by various types of plumbing fixtures. The drainage fixture unit value for a particular fixture depends on its volume rate of drainage discharge, on the time duration of a single drainage operation and on the average time between successive operations.

5D.2.1.57 Float Operated Valve —

Ball valves or ball taps and equilibrium valves operated by means of a float.

5D.2.1.58 Flushing Cistern —

A cistern provided with a device for rapidly discharging the contained water and used in connection with a sanitary appliance for the purpose of cleaning the appliance and carrying away its contents into a drain.

NOTE — The nominal size of a cistern is the quantity of water discharged per flush.

5D.2.1.59 Formation —

The finished level of the excavation at the bottom of a trench or heading prepared to receive the permanent work.

5D.2.1.60 French Drain or Rubble Drain —

A shallow trench filled with coarse rubble, clinker, or similar material with or without field drain pipes.

5D.2.1.61 Frost Line —

The line joining the points of greatest depths below ground level up to which the moisture in the soil freezes.

5D.2.1.62 General Washing Place —

A washing place provided with necessary sanitary arrangement and common to more than one tenement.

5D.2.1.63 Geyser —

An apparatus for heating water with supply control on the inlet side and delivering it from an outlet.

5D.2.1.64 Gully Chamber —

The chamber built of masonry round a gully trap for housing the same.

5D.2.1.65 Gully Trap —

A trap provided in a drainage system with a water seal fixed in a suitable position to collect waste-water from the scullery, kitchen sink, wash basins, baths and rain water pipes.

5D.2.1.66 Haunching —

Outward sloping concrete support to the sides of a pipe or channel above the concrete bedding.

5D.2.1.67 Heel Rest Bend or Duck-Foot Bend —

A bend, having a foot formed integrally in its base, used to receive a vertical pipe.

5D.2.1.68 High Altitudes —

Elevations higher than 1 500 m above mean sea level (MSL).

5D.2.1.69 Highway Authority —

The public body in which is vested, or which is the owner of, a highway repairable by the inhabitants collectively; otherwise the body or persons responsible for the upkeep of the highway.

5D.2.1.70 Horizontal Pipe —

Any pipe or fitting which makes an angle of more than 45° with the vertical.

5D.2.1.71 Hot Water Tank —

A vessel for storing hot water under pressure greater than atmospheric pressure.

5D.2.1.72 Inlet Hopper—

A receptacle fitting for receiving refuse from each floor and dropping it into the chute.

5D.2.1.73 Inspection Chamber—

A water-tight chamber constructed in any house-drainage system which takes wastes from gully traps and disposes of to manhole with access for inspection and maintenance.

5D.2.1.74 Interceptor —

A device designed and installed so as to separate and retain deleterious, hazardous or undesirable matter from normal wastes and permit normal sewage or liquid wastes to discharge into the disposal terminal by gravity.

5D.2.1.75 Interceptor Manhole or Interceptor Chamber —

A manhole incorporating an intercepting trap and providing means of access thereto.

5D.2.1.76 Invert —

The lowest point of the internal surface of a pipe or channel at any cross-section.

5D.2.1.77 Junction Pipe —

A pipe incorporating one or more branches.

5D.2.1.78 Lagging —

Thermal insulation on pipes.

5D.2.1.79 Licensed Plumber —

A person licensed under the provisions of this Code.

5D.2.1.80 Main Soil Pipe (MSP) —

A pipe connecting one or more branch soil pipes to the drain.

5D.2.1.81 Main Soil and Waste Pipe (MSWP) —

A pipe connecting one or more branch soil and waste pipes to the drain.

5D.2.1.84 Main Ventilating Pipe (MVP) —

A pipe which receives a number of branch ventilating pipes.

5D.2.1.83 Main Waste Pipe (MWP) —

A pipe connecting one or more branch waste pipes to the drain.

5D.2.1.84 Manhole —

An opening by which a man may enter or leave a drain, a sewer or other closed structure for inspection, cleaning and other maintenance operations, fitted with suitable cover.

5D.2.1.85 Manhole Chamber —

A chamber constructed on a drain or sewer so as to provide access thereto for inspection, testing or clearance of obstruction.

5D.2.1.86 Non-Service Latrine —

Other than 'service latrine'.

5D.2.1.87 Offset —

A pipe fitting used to connect two pipes whose axes are parallel but not in line.

5D.2.1.88 Period of Supply —

The period of the day or night during which water supply is made available to the consumer.

5D.2.1.89 Pipe System —

The system to be adopted will depend on the type and planning of the building in which it is to be installed and will be one of the following:

- a) **Single stack system (see Fig. 2)** — The one- pipe system in which there is no trap ventilation.
- b) **Single stack — Partially Vented** — A via media between the one-pipe system and the single stack system (*see* one-pipe system, partially ventilated).
- c) **One-pipe system (see Fig. 3)** — The system of plumbing in which the wastes from the sinks, baths and wish basins, and the soil pipe branches are all collected into one main pipe, which is connected, directly to the drainage system. Gully traps and waste pipes are completely dispersed with, but all the traps of the water closets, basins, etc, are completely ventilated to preserve the water seal.
- d) **One-pipe system — Partially vented (also called single stack, partially ventilated)** — A system in which there is one soil pipe into which all water closets, baths, sinks, and basins discharge. In addition, there is a relief vent, which ventilates only the traps of water closets.
- e) **Two-pipe system (see Fig. 4)** — The system of plumbing in which soil and waste pipes are distinct and separate. The soil pipes being connected to the drain direct and waste pipes through a trapped gully. All traps of all appliances are completely ventilated in this system.

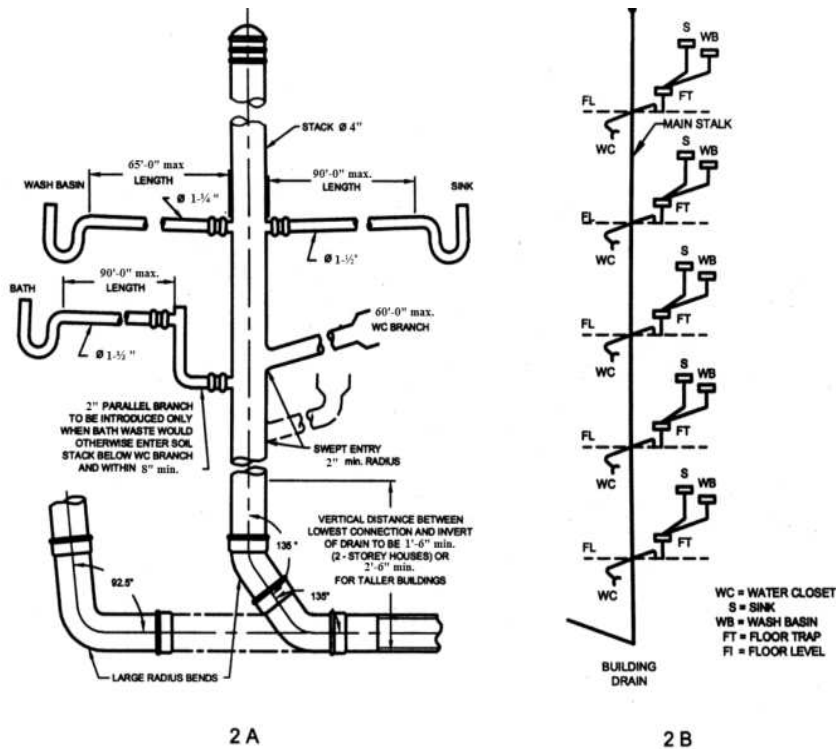

Figure 2 Single Stack System – Main Feature Of Design

5D.2.1.90 Pipe Work —

Any installation of piping with its fittings.

5D.2.1.91 Plumbing

- a) The pipes, fixtures and other apparatus inside a building for bringing in the water supply and removing the liquid and water borne wastes.
- b) The installation of the foregoing pipes, fixtures and other apparatus.

5D.2.1.92 Plumbing System —

The plumbing system shall include the water supply and distribution pipes; plumbing fittings and traps; soil, waste, vent pipes and anti-siphonage pipes; building drains and building sewers including their respective connections, devices and appurtenances within the property lines of the premises; and water-treating or water-using equipment.

5D.2.1.93 Potable Water —

Water which is satisfactory for drinking, culinary and domestic purposes and meets the requirements of the Authority.

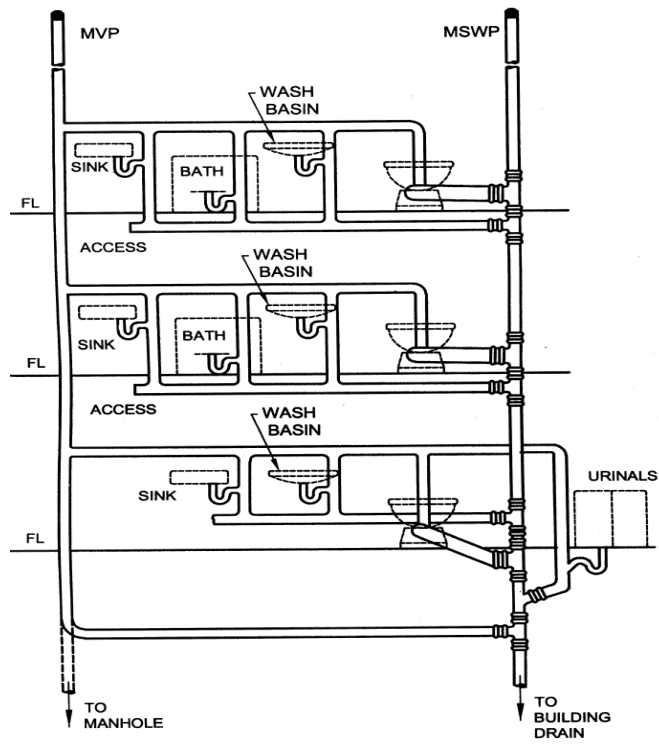

Figure 3 Diagram Of One-Pipe System

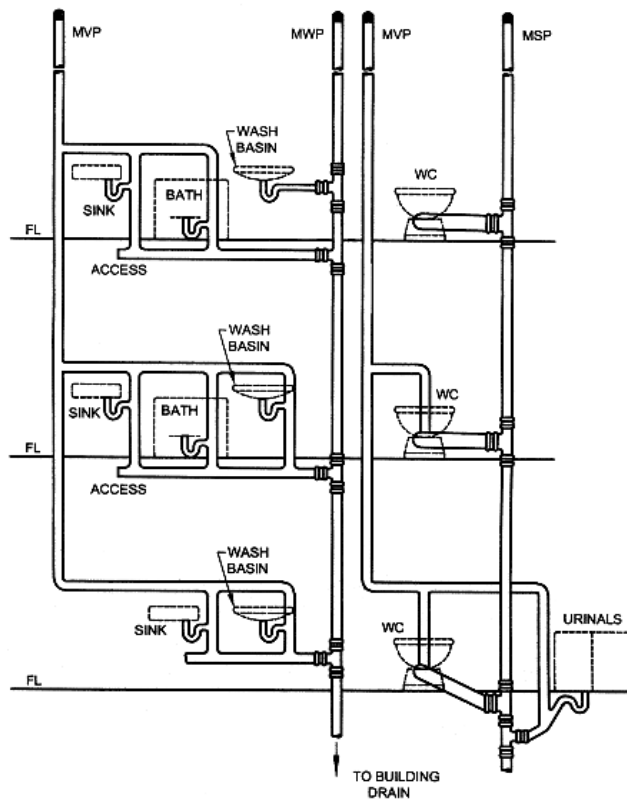

Figure 4 Diagram Of Two-Pipe System

5D.2.1.94 Premises

Premises shall include passages, buildings and lands of any tenure, whether open or enclosed, whether built on or not, and whether public or private in respect of which a water rate or charge is payable to the Authority or for which an application is made for supply of water.

5D.2.1.95 Puff Ventilation

The ventilation provided for waste traps in two-pipe system, in order to preserve the water seal.

5D.2.1.96 Residual Head

The head available at any particular point in the distribution system.

5D.2.1.97 Saddle

A purpose made fitting, so shaped as to fit over a hole cut in a sewer or drain used to form connections.

5D.2.1.98 Sanitary Appliances

The appliances for the collection and discharge of soil or waste matter.

5D.2.1.99 Service Latrine

A latrine from which the excreta are removed by manual agency and not by water carriage.

5D.2.1.100 Service Pipe

Pipe that runs between the distribution main in the street and the riser in case of a multi-storeyed building or the water meter in the case of an individual house and is subject to water pressure from such main.

5D.2.1.101 Sewer

A pipe or conduit, generally closed, but normally not flowing full for carrying sewage and/ or other waste liquids.

5D.2.1.102 Slop Hopper (Slop Sink)

A hopper shaped sink, with a flushing run and outlet similar to those of a WC pan, for the reception and discharge of human excreta.

5D.2.1.103 Soakaway

A pit, dug into permeable ground lined to form a covered perforated chamber or filled with hard-core, to which liquid is led, and from which it may soak away into the ground.

5D.2.1.104 Soffit (Crown)

The highest point of the internal surface of a sewer or culvert at any cross- section.

5D.2.1.105 Soil Appliances

A sanitary appliance for the collection and discharge of excretory matter.

5D.2.1.106 Soil Pipe

A pipe that conveys the discharge of water closets or fixtures having similar functions, with or without the discharges from other fixtures.

5D.2.1.107 Soil Waste

The discharge from water closets, urinals, slop hooper, stable yard or cowshed gullies and similar appliances.

5D.2.1.108 Stop-Cock

A cock fitted in a pipe line for controlling the flow of water.

5D.2.1.109 Stop Tap

Stop tap includes stop-cock, stop valve or any other device for stopping the flow of water in a line or system of pipes at will.

5D.2.1.110 Storage Tank

A container used for storage of water which is connected to the water main or tube- well by means of supply pipe.

5D.2.1.111 Sub-Soil Water

Water occurring naturally in the sub-soil.

5D.2.1.112 Sub-Soil Water Drain

- a) A drain intended to collect and carry away sub-soil water.
- b) A drain intended to disperse into the sub-soil from a septic tank.

5D.2.1.113 Sub-Zero Temperature Regions

Regions where temperatures fall below 0°C and freezing conditions occur.

5D.2.1.114 Sullage

See 5D.2.1.129.

5D.2.1.115 Supply Pipe

So much of any service pipe as is not a communication pipe.

5D.2.1.116 Supports

Hangers and anchors or devices for supporting and securing pipe and fittings to walls, ceilings, floors or structural members.

5D.2.1.117 Surface Water

Natural water from the ground surface, paved areas and roofs.

5D.2.1.118 Surface Water Drain

A drain conveying surface water including storm water.

5D.2.1.119 Systems of Drainage

- a) **Combined system** — A system in which foul water (sewage) and surface water are conveyed by the same sewers and drains.
- b) **Separate system** — A system in which foul water (sewage) and surface water are conveyed by the separate sewers and drains.
- c) **Partially separate system** — A modification of the separate system in which part of the surface water is conveyed by the foul (sanitary) sewers and drains.

5D.2.1.120 Trade Effluent

Any liquid either with or without particles of matter in suspension which is wholly or in part produced in the course of any trade or industry, at trade premise. It includes farm wastes but does not include domestic sewage.

5D.2.1.121 Trap

A fittings or device so designed and constructed as to provide, when properly vented, a liquid seal which will prevent the back passage of air without materially affecting the flow of sewage or waste water through it.

5D.2.1.122 Vertical Pipe

Any pipe or fitting which is installed in a vertical position or which makes an angle or not more than 45° with the vertical.

5D.2.1.123 Vent Slack/Vent Pipe

A vertical vent pipe installed primarily for the purpose of proving circulation of air to and from any part of the drainage system. It also protects trap seals from excessive pressure fluctuation.

5D.2.1.124 Vent System

A pipe or pipes installed to provide a flow of air to or from a drainage system or to provide a circulation of air with in such system to protect traps seals from siphonage and back-pressure.

5D.2.1.125 Warning Pipe

An overflow pipe so fixed that its outlet, whether inside or outside a building, is in a conspicuous position where the discharge of any water therefrom can be readily seen.

5D.2.1.126 Wash-Out Valve

A device located at the bottom of the tank for the purpose of draining a tank for cleaning, maintenance, etc.

5D.2.1.127 Waste Appliance

A sanitary appliance for the collection and discharge of water after use for ablutionary, culinary and other domestic purpose.

5D.2.1.128 Waste Pipe

In plumbing, any pipe that receives the discharge of any fixtures, except water- closets or similar fixtures and conveys the same to the house drain or soil or waste stack. When such pipe does not connect directly with a house drain or soil stack, it is called an indirect waste pipe.

5D.2.1.129 Waste-Water (Sullage)

The discharge from wash basins, sinks and similar appliances, which does not contain human or animal excreta.

5D.2.1.130 Water Main (Street Main)

A pipe laid by the water undertakers for the purpose of giving a general supply of water as distinct from a supply to individual consumers and includes any apparatus used in connection with such a pipe.

5D.2.1.131 Water Outlet

A water outlet, as used in connection with the water distributing system, is the discharge opening for the water (a) to a fitting; (b) to atmospheric pressure (except into an open tank which is part of the water supply system); and (c) to any water- operated device or equipment requiring water to operate.

5D.2.1.132 Water Seal

The water in a trap, which acts as a barrier to the passage of air through the trap.

5D.2.1.133 Water Supply System

Water supply system of a building or premises consists of the water service pipe, the water distribution pipes, and the necessary connecting pipes, fittings, control valves, and all appurtenances in or adjacent to the building or premises.

5D.2.1.134 Waterworks

Waterworks for public water supply include a lake, river, spring, well, pump with or without motor and accessories, reservoir, cistern, tank, duct whether covered or open, sluice, water main, pipe, culvert, engine and any machinery, land, building or a thing used for storage, treatment and supply of water.

5D.3 GENERAL**5D.3.1 Basic Principles****5D.3.1.1 Potable Water**

All premises intended for human habitation, occupancy, or use shall be provided with supply of potable water. This water supply shall not be connected with unsafe water resources, nor shall it be subject to the hazards of backflow.

5D.3.1.2 Water Provision

Plumbing fixtures, devices and appurtenances shall be provided with water in sufficient volume and at pressures adequate to enable them to function properly and without undue noise under normal conditions of use.

There should be at least a residual head of **6 ft** at the consumer's tap.

NOTE — The residual head shall be taken at the highest/farthest outlets in the building.

5D.3.1.3 Water Conservation

Plumbing system shall be designed, installed and adjusted to use the optimum quantity of water consistent with proper performance and cleaning.

5D.3.1.4 Safety Devices

Plumbing system shall be designed and installed with safety devices to safeguard against dangers from contamination, explosion, overheating, etc.

5D.3.1.5 Plumbing Fixtures

It is recommended that each family dwelling unit should have at least one water closet, one lavatory, one kitchen wash place or a sink, and one bathing wash place or shower to meet the basic requirements of sanitation and personal hygiene.

5D.3.1.6 Drainage System

The drainage system shall be designed, installed and maintained to guard against fouling, deposit of solids and clogging and with adequate cleanouts so arranged that the pipes may be readily cleaned.

5D.3.1.7 Materials and Workmanship

The plumbing system shall have durable material, free from defective workmanship and so designed and installed as to give satisfactory service for its reasonable expected life.

5D.3.1.8 Fixture Traps and Vent Pipes

Each fixture directly connected to the drainage system shall be equipped with a liquid seal trap. Trap seals shall be maintained to prevent sewer gas, other potentially dangerous or noxious fumes, or vermin from entering the building. Further, the drainage system shall be designed to provide an adequate circulation of air in all pipes with no danger of siphonage, aspiration, or forcing of trap seals under conditions of ordinary use by providing vent pipes throughout the system.

5D.3.1.9 Foul Air Exhaust

Each vent terminal shall extend to the outer air and be so installed as to minimize the possibilities of clogging and the return of foul air to the building, as it conveys potentially noxious or explosive gases to the outside atmosphere. All vent pipes shall be provided with a cowl.

5D.3.1.10 Testing

The plumbing system shall be subjected to required tests to effectively disclose all leaks and defects in the work or the material.

5D.3.1.11 Exclusion from Plumbing System

No substance that will clog or accentuate clogging of pipes, produce explosive mixtures, destroy the pipes or their joints, or interfere unduly with the sewage-disposal process shall be allowed to enter the drainage system.

5D.3.1.12 Light and Ventilation

Wherever water closet or similar fixture shall be located in a room or compartment, it should be properly lighted and ventilated.

5D.3.1.13 Individual Sewage Disposal Systems

If water closets or other plumbing fixtures are installed in buildings where connection to public sewer is not possible, suitable provision shall be made for acceptable treatment and disposal.

5D.3.1.14 Maintenance

Plumbing systems shall be maintained in a safe and serviceable condition.

5D.3.1.15 Accessibility

All plumbing fixtures shall be so installed with regard to spacing as to be accessible for their intended use and for cleaning. All doors, windows and any other device needing access within the toilet shall be so located that they have proper access.

5D.3.1.16 Fixture for Disabled

Special toilet fixtures shall be provided for the disabled with required fixtures and devices.

5D.3.1.17 Structural Safety

Plumbing system shall be installed with due regard to preservation of the structural members and prevention of damage to walls and other surfaces.

5D.3.1.18 Protection of Ground and Surface Water

Sewage or other waste shall not be discharged into surface or sub-surface water without acceptable form of treatment.

5D.3.2 Water Supply Connection**5D.3.2.1 Application for Obtaining Supply Connection**

Every consumer, requiring a new supply of water or any extension or alteration to the existing supply shall apply in writing in the prescribed form (*see Annex A*) to the Authority.

5D.3.2.2 Bulk Supply

In the case of large housing colonies or where new services are so situated that it will be necessary for the Authority to lay new mains or extend an existing main, full information about the proposed housing scheme shall be furnished to the Authority; information shall also be given regarding their phased requirements of water supply with full justification. Such information shall include site plans, showing the layout of roads, footpaths, building and boundaries and indicating thereon the finished line and level of the roads or footpaths and water supply lines and appurtenances.

5D.3.2.3 Completion Certificate

On completion of the plumbing work for the water supply system, the licensed plumber shall give a completion certificate in the prescribed form to the Authority for getting the water connection from the mains.

5D.3.3 Drainage and Sanitation**5D.3.3.1 Preparation and Submission of Plan**

No person shall install or carry out any water-borne sanitary installation or drainage installation or any works in connection with anything existing or new buildings or any other premises without obtaining the previous sanction of the Authority.

The owner shall make an application in the prescribed form to the Authority to carry out such a work.

5D.3.3.2 Site Plan

A site plan of the premises on which the building is to be situated or any such work is to be carried out shall be prepared drawn to a scale not smaller than 1":40' (*see Part 2 'Administration'*). The site plan of the building premises shall show:

- a) the adjoining plots and streets with their names;
- b) the position of the municipal sewer and the direction of flow in it;
- c) the invert level of the municipal sewer, the road level, and the connection level of the proposed drain connecting the building in relation to the sewer,
- d) the angle at which the drain from the building joints the sewer; and
- e) the alignment, sizes and gradients of all drains and also of surface drains, if any.

A separate site plan is not necessary if the necessary particulars to be shown in such a site plan are already shown in the drainage plan.

5D.3.3.3 Drainage Plan

The application (3.3.1) shall be accompanied by a drainage plan drawn to a scale of not smaller than 1":8' and furnished along with the building plan (see Part 2 'Administration'). The plans shall show the following:

- a) Every floor of the building in which the pipes or drains are to be used;
- b) The position, forms, level and arrangement of the various parts of such building, including the roof thereof;
- c) All new drains as proposed with their sizes and gradients;
- d) Invert levels of the proposed drains with corresponding ground levels;
- e) The position of every manhole, gully, soil and waste pipe, ventilating pipe, rain water pipe, water-closet, urinal, latrine, bath, lavatory, sink, trap or other appliances in the premises proposed to be connected to any drain and the following colours are recommended for indicating sewers, waste water pipes, rainwater pipes an existing work.

Description of Work	Colour
Sewers	Red
Waste water pipes and rain-water pipes	Blue
Existing work	Black

- f) The position of refuse chute, inlet hopper and collection chamber.

5D.3.3.3.1

In the case of an alteration or addition to an existing building, this clause shall be deemed to be satisfied if the plans as furnished convey sufficient information for the proposals to be readily identified with previous sanctioned plans and provided the locations of tanks and other fittings are consistent with the structural safety of the building.

5D.3.3.3.2

The plans for the building drainage shall in every case be accompanied by specifications for the various items of work involved. This information shall be supplied in the prescribed form.

5D.3.3.4

In respect of open drains, cross-sectional details shall be prepared to a scale not smaller than 1":4' showing the ground and invert levels and any arrangement already existing or proposed for the inclusion of any or exclusion of all storm water from the sewers.

5D.3.3.5 Completion Certificate

At the completion of the plumbing installation work, the licensed plumber shall give a completion certificate in the prescribed form.

5D.3.4 Licensing/Registration of Plumbers

5D.3.4.1 Execution of Work

The work which is required to be carried out under the provisions of this Section, shall be executed only by a licensed plumber under the control of the Authority and shall be responsible

to carry out all lawful directions given by the Authority. No individual shall engage in the business of plumbing unless so licensed under the provisions of this Section.

5D.3.4.1.1

No individual, firm, partnership or corporation shall engage in the business of installing, repairing or altering plumbing unless the plumbing work performed in the course of such business is under the direct supervision of a licensed plumber and who has been assigned duties by authority.

5D.3.4.2 Examination and Certification

The Authority shall establish standards and procedure for the qualification, examination and licensing of plumbers and shall issue licenses to such persons who meet the qualifications thereof and successfully pass the examination.

5D.3.4.3

For guidelines for registration of plumbers including the minimum standards for qualifications for the grant of licenses, reference may be made to Authority concerned .

5D.4 WATER SUPPLY

5D.4.1 Water Supply Requirements for Buildings

5D.4.1.1 Water Supply for Residences

A **minimum of 15gal to 22gallons per capita per day (gpcd) may** be considered adequate for domestic needs of urban communities, apart from non-domestic needs as flushing requirements. As a general rule the following rates per capita per day may be considered minimum for domestic and non-domestic needs:

- a) For communities with population up to 20 000 and without flushing system:
 - 1) water supply through stand post 9 gpcd , *Min*
 - 2) water supply through house service connection 15 to 20 gpcd
- b) For communities with population 20 000 to 100 000 20 to 30 gpcd
together with full flushing system
- c) For communities with population above 100 000 30 to 40 gpcd
together with full flushing system

NOTE — The value of water supply given as 30 to 40 gallons per capita per day may be reduced to 30 gallons per capita per day for houses for Lower Income Groups (LIG) and Economically Weaker Section of Society (EWS), depending upon prevailing conditions.

5D.4.1.1.1

Out of the 33 to 44 gallons per capita per day, 10 gallons per capita per day may be taken for flushing requirements and the remaining quantity for other domestic purposes.

5D.4.1.2 Water Supply for Buildings Other than Residences

Minimum requirements for water supply for buildings other than residences shall be in accordance with Table 1.

Table 1: Water Requirements for Buildings Other than Residences**(Clause 4.1.2)**

SI No. (1)	Type of Building (2)	Consumption per Day, gallons (3)
i)	Factories where bath rooms are required to be provided	10 per head
ii)	Factories where no bath rooms are required to be provided	7 per head
iii)	Hospital (including laundry):	
	a) Number of beds not exceeding 100	75 per head
	b) Number of beds exceeding 100	100 per head
iv)	Nurses' homes and medical quarters	30 per head
v)	Hostels	30 per head
vi)	Hotel (up to 4 Star)	40 per head
vii)	Hotel (5 Star and above)	70 per head
viii)	Offices	10 per head
ix)	Restaurants	15 per head
x)	Cinemas, concert halls and theatres	3 per head
xi)	Schools:	
	a) Day schools	10 per head
	b) Boarding schools	30 per head

NOTE — For calculating water demand for visitors a consumption of 3 gallons per head, per day may be taken.

5D.4.1.3 Water Supply Requirements of Traffic Terminal Stations

The water supply requirements of traffic terminal stations (railway stations, bus stations, harbours, airports, etc) include provisions for waiting rooms and waiting halls. They do not, however, include requirements for retiring rooms. Requirements of water supply for traffic terminal stations shall be according to Table 2.

Table 2: Water Supply Requirements for Traffic Terminal Stations**(Clause 4.1.3)**

SI No. (1)	Nature of Station/Terminal (2)	Where Bathing Facilities are Provided gallons/capita (3)	Where Bathing Facilities are not Provided gallons/capita (4)
i)	Intermediate stations (excluding mail and express stops)	10	5
ii)	Junction stations and intermediate stations where mail or express stoppage is provided	15	10
iii)	Terminal stations	10	10
iv)	International and domestic airports	15	15

NOTES

- 1 The number of persons shall be determined by average number of passengers handled by the station daily; due consideration may be given to the staff and vendors likely to use facilities.
- 2 Consideration should be given for seasonal average peak requirements.

5D.4.1.4 Water Supply for Fire Fighting Purposes**5D.4.1.4.1**

The Authority shall make provision to meet the water supply requirements for fire fighting in the city/area, depending on the population density and types of occupancy.

5D.4.1.4.2

Provision shall be made by the owner of the building for water supply requirements for fire fighting purposes within the building, depending upon the height and occupancy of the building, in conformity with the requirements laid down in Part 4 'Fire and Life Safety'.

5D.4.1.4.3

The requirements regarding water supply in storage tanks, capacity of fire pumps, arrangements of wet riser-cum-down comer and wet riser installations for buildings above 50ft in height, depending upon the occupancy use, shall be in accordance with Part 4 'Fire and Life Safety'.

5D.4.1.5 Water Supply for Other Purposes**5D.4.1.5.1**

Water supply in many buildings is also required for many other applications other than domestic use, which must be identified in the initial stages of planning so as to provide the requisite water quantity, storage capacity and pressure as required for each application. In such instances information about the water use and the quality required may be obtained from the users. Some typical uses other than domestic use and fire fighting purposes are air conditioning and air washing, swimming pools and water bodies and gardening.

5D.4.2 Water Sources and Quality**5D.4.2.1 Sources of Water**

The origin of all sources of water is rainfall. Water can be collected as it falls as rain before it reaches the ground; or as surface water when it flows over the ground or is pooled in lakes or ponds; or as ground water when it percolates into the ground and flows or collects as ground water; or from the sea into which it finally flows.

5D.4.2.2

The quality of water to be used for drinking shall be as per good practices [9-1(2)].

5D.4.2.3

For purposes other than drinking, water if supplied separately, shall be absolutely safe from bacteriological contamination so as to ensure that there is no danger to the health of the users due to such contaminants.

5D.4.2.4 Waste Water Reclamation

Treated sewage or other waste water of the community may be utilized for non-domestic purposes such as water for cooling, flushing, lawns, parks, fire fighting and for certain

industrial purposes after giving the necessary treatment to suit the nature of the use. This supply system shall be allowed in residences only if proper provision is made to avoid any cross connection of this treated waste water with domestic water supply system.

5D.4.2.5

Whenever a building is used after long intervals, the water quality of the stored water must be checked so as to ensure that the water is safe for use as per water quality requirements specified in this Code.

5D.4.3 Estimate of Demand Load

5D.4.3.1

Estimates of total water supply requirements for buildings shall be based on the occupant load consistent with the provisions of 4.1.

5D.4.3.1.1

For residential buildings, the requirements of water shall be based on the actual number of occupants; where this information is not available, the number of occupants for each residential unit may be based on a family of five. For assessing the population in other occupants, reference may be made to Part 4 'Fire and Life Safety'.

5D.4.3.1.2

In making assessment of water supply requirements of large complexes, the future occupant load shall be kept in view. Use may be made of the following methods for estimating future requirements:

- a) demographic method of population projection,
- b) arithmetic progression method,
- c) geometrical progression method,
- d) method of varying increment or incremental increase,
- e) logistic method,
- f) graphical projection method, and
- g) graphical comparison method.

5D.4.4 Storage of Water

5D.4.4.1

In a building, provision is required to be made for storage of water for the following reasons:

- a) to provide against interruptions of the supply caused by repairs to mains, etc;
- b) to reduce the maximum rate of demand on the mains;
- c) to tide over periods of intermittent supply; and
- d) to maintain a storage for the fire fighting requirement of the building (*see* Part 4 'Fire and Life Safety').

5D.4.4.2

The water may be stored either in overhead tanks (OHT) and/or underground tanks (UGT).

5D.4.4.3 Materials Used

Reservoirs and tanks for the reception and storage of water shall be constructed of reinforced concrete brick masonry, ferrocement precast, mild steel, stainless steel, galvanized iron or plastic.

5D.4.4.3.1

Tanks made of steel may be of welded, riveted or pressed construction. The metal shall be galvanized coated externally with a good quality anti-corrosive weather-resisting paint. Lead-based paint shall not be used in the tank. Lead-lined tanks shall not be used. Rectangular pressed steel tanks shall conform to good practice [9-1(3)].

5D.4.4.4 Each tank shall be provided with the following:

- a) *Manholes* — Adequate number of manholes for access and repair. The manholes shall be made of corrosion resistant material (for example, cast iron, reinforced cement concrete, steel fibre reinforced concrete, galvanized steel, high density polyethylene, fibre glass reinforced plastic or such other materials acceptable to the Authority). Manholes shall be provided with locking arrangement to avoid misuse and tampering.
- b) *Catch Rings and Ladders* — Tanks higher than 3 feet deep shall be provided with corrosion resistant catch rings, steps or ladders according to the depth to enable a person to reach the bottom of the tank.
- c) *Overflow Pipe* — Each tank shall be provided with an overflow pipe terminating above the ground/terrace level to act as a 'Warning Pipe' to indicate overflow conditions. The size of the overflow pipe shall be adequate to accept the flow. Normally the overflow pipe size shall be one size higher than the inlet pipe. When the inlet pipe diameter is large, two or more overflow pipes of equivalent cross-section may be provided.
- d) *Vent Pipes* — Tanks larger than 1200 gallons capacity shall be provided with vent pipes to prevent development pressure in the tank which might result in NO FLOW condition or inward collapse of the tank.

Scour Pipe — Each tank shall be provided with a scour pipe with an accessible valve for emptying the tank.

- e) *Connection of Overflow and Scour Pipe* — Under no circumstances tank overflow and scour pipe shall be connected to any drain, gully trap or manhole to prevent back flow and contamination of the water. All such connections shall be discharged over a grating with an air gap of 2 inches. All overflow and vent pipes shall be provided with a mosquito proof brass grating to prevent ingress of mosquito, vermin and other insects.
- f) The top slab of the tank must be suitably sloped away from its centre for proper drainage of the rainwater.
- g) Tanks on terraces and above ground shall be supported by appropriate structural members so as to transfer the load of the tank and the water directly on the structural members of the building.

5D.4.4.5

Every storage tank shall be easily accessible and placed in such a position as to enable thorough inspection and cleaning to be carried out. If the storage capacity required is more than 1200 gallons, it is advantageous to arrange it in a series of tanks so interconnected that each tank can

be isolated for cleaning and inspection without interfering with the supply of water. In large storage tanks, the outlet shall be at the end opposite the inlet to avoid stagnation of the water.

5D.4.4.6

The outlet pipe shall be fixed 2 inches to 3 inches above the bottom of the tank and fitted with a strainer, preferably of brass.

5D.4.4.7

In the case of underground storage tanks, the design of the tank shall be such as to provide for the draining of the tank when necessary and water shall not be allowed to collect around the tank. The tank shall be perfectly water-proof and shall be provided with a cement concrete cover, having a manhole opening, with a properly fitting hinged cast iron cover on a leak-proof cast iron frame.

The underground tanks should not be located in low lying areas or near any public or private sewer, septic tank, leaching pool or soakage pit to prevent any contamination. The overflow of the tank should be well above (preferably 2 feet) the external surface level and terminate as a warning pipe with a mosquito proof grating. Care must be taken to prevent backflow of local surface water into the tank in case of local flooding. Otherwise the overflow must be terminated in a more safer manner as per the site conditions. For tanks with at least one side exposed to a basement, it is safer to discharge the overflow into the basement level.

The tank top slab shall also be designed to carry the load due to fire tender movement where anticipated as in the case of an extended basement.

There should be no common wall between the tanks storing safe water and tanks storing water from unsafe sources.

In the case of storage tanks built under the floor slab, it must have at least 2 feet space around the perimeter of the tank to enable regular inspection and maintenance. It must have at least 3 feet vertical space between the floor slab and cover slab of the tank to enable regular inspection and maintenance.

5D.4.4.8

In case of overhead tanks, bottom of the tanks shall be placed clear off the terrace slab such that the elevation difference between the outlet pipe of the tank and the highest fixture at the top floor of the building is minimum 6 feet, which shall also prevent leakage into the structural slab. In tall buildings, the top of the tank shall be provided with the safe ladder or staircase. The top slab shall be provided with railing or a parapet wall.

5D.4.4.9

For jointing steel pipe to a storage tank, the end of the pipe shall be screwed, passed through a hole in the tank and secured by backnuts, both inside and outside. The pipe end shall be flush with the face of the inside backnut. For jointing copper pipe to steel or copper tank, a connector of non-ferrous material shall be used. The connector shall have a shoulder to bear on the outside of the tank and shall be secured by a backnut inside.

5D.4.4.10

The quantity of water to be stored shall be calculated taking into account the following factors:

- a) hours of supply at sufficiently high pressure to fill up the overhead storage tanks;
- b) frequency of replenishment of overhead tanks, during the 24 h;

- c) rate and regularity of supply; and
- d) consequences of exhausting storage particularly in case of public buildings like hospitals.

If the water supply is intermittent and the hours of supply are irregular, it is desirable to have a minimum storage of half a day's supply for overhead tanks. For additional requirement of water storage for firefighting purposes, reference may be made to Part 4 'Fire and Life Safety'.

NOTE — General guidelines for calculation of capacity of these storage tanks are as follows:

- a) In case only OHT is provided, it may be taken as minimum one day's requirement;
- b) In case only UGT is provided, it may be taken as minimum 150 percent of one day's requirement; and
- c) In case combined storage is provided, it may be taken as minimum 100 percent UGT and minimum 50 percent OHT of one day's requirement.

5D.4.4.11

When only one communication pipe is provided for water supply to a building, it is not necessary to have separate storage for flushing and sanitary purposes for health reasons. In such cases when only one storage tank has been provided, tapping of water may be done at two different levels (the lower tapping for flushing) so that a part of the water will be exclusively available for flushing purposes.

5D.4.5 Materials, Fittings and Appliances

5D.4.5.1 Standards for Materials, Fittings and Appliances

All materials, water fittings and appliances shall conform to Part 5 'Building Materials'.

5D.4.5.2 Materials for Pipes

Pipes may be of any of the following materials:

- a) cast iron, vertically cast or centrifugally (spun) cast,
- b) steel (internally lined or coated with bitumen or a bituminous composition, and out-coated with cement concrete or mortar, where necessary),
- c) reinforced concrete,
- d) prestressed concrete,
- e) galvanized mild steel tubes,
- f) copper,
- g) brass,
- h) wrought iron,
- i) asbestos cement,
- j) polyethylene,
- k) unplasticized PVC,
- l) chlorinated PVC, or
- m) stainless steel.

5D.4.5.2.1

The material chosen shall be resistant to corrosion, both inside and outside or shall be suitably protected against corrosion.

5D.4.5.2.2

Polyethylene and unplasticized PVC pipes shall not be installed near hot water pipes or near any other heat sources. For temperature limitations in the use of polyethylene and unplasticized PVC pipes to convey water, reference may be made to good practice [9-1(4)].

5D.4.6 Design of Distribution Systems**5D.4.6.1 General**

All buildings shall conform to the general requirements given in **3.1**.

5D.4.6.2 Rate of Flow

One of the important items that needs to be determined before the sizes of pipes and fittings for any part of the water piping system may be decided upon, is the rate of flow in the service pipe which, in turn depends upon the number of hours for which the supply is available at sufficiently high pressure. If the number of hours for which the supply is available is less, there will be large number of fittings in use simultaneously and the rate of flow will be correspondingly large.

The data required for determining the size of the communication and service pipes are:

- a) the maximum rate of discharge required;
- b) the length of the pipe; and
- c) the head loss by friction in pipes, fittings and meters.

5D.4.6.3 Discharge Computation**5D.4.6.3.1 Design of consumer's pipes based on fixture units**

The design of the consumers' pipes or the supply pipe to the fixtures is based on:

- a) the number and kind of fixtures installed;
- b) the fixture unit flow rate; and
- c) the probable simultaneous use of these fixtures.

The rates at which water is desirably drawn into different types of fixtures are known. These rates become whole numbers of small size when they are expressed in fixture unit.

The fixture units for different sanitary appliances or groups of appliances are given in Table 3 and Table 4.

Table 3: Fixture Unit for Different Types of Fixtures with Inlet Pipe Diameter
(CLAUSE 4.6.3.1)

SI No. (1)	Type of Fixture (2)	Fixture Unit FU as Load Factor (3)	Minimum Normal Size of Fixture Branch, in (4)
i)	Ablution tap	1	½
ii)	Bath tub supply by spout <i>Shower over tub does not add to the load</i>	3	½
iii)	Shower stall domestic	2	½
iv)	Shower in groups per head	3	½
v)	Wash basin domestic use	1	½
vi)	Wash basin public use	2	½
vii)	Wash basin surgical	2	½
viii)	Scrub station in hospitals per outlet	3	½
ix)	Drinking water fountain/water cooler	0.5	½
x)	Water-closet with cistern (single/double flush)	1	½
xi)	Water-closet with flush or magic eye operated valve	8	1 / 1¼
xii)	Urinals with auto flushing cisterns	4	½ / ¾
xiii)	Urinals with flush or magic eye operated valve	2	½ / ¾
xiv)	Kitchen sink (domestic use)	2	½ / ¾
xv)	Washing machine	3	½ / ¾

Table 4: Fixture Unit for Different Types of Fixtures Based on Pipe or Trap Diameter
(CLAUSE 4.6.3.1)

SI No. (1)	Drain or Trap Outlet Diameter(inches) (2)	Fixture Unit (FU) (3)
i)	1¼ or smaller	1
ii)	1½	2
iii)	2	3
iv)	2½	4
v)	3	5
vi)	4	6

NOTE — Before using the above figures check the actual flow from the outlets of special equipment, for example, small period high discharges, for example, from washing machines, boiler blow downs, filter backwash and water tank emptying operations.

**Table 5: Probable Simultaneous Demand
(Clause 4.6.3.2)**

No. of Fixture Units (1)	System with Flush Tanks Demand (Based on Fixture Units)		System with Valves Demand (After Hunter)	
	Unit Rate Flow ¹⁾ (2)	Flow in gallon per minute (3)	Unit Rate Flow ¹⁾ (4)	Flow in gallon per minute (5)
20	2.0	12.45	4.7	29.28
40	3.3	20.55	6.3	39.25
60	4.3	26.80	7.4	46.09
80	5.1	31.77	8.3	51.70
100	5.7	35.51	9.1	56.69
120	6.4	39.86	9.8	61.05
140	7.1	44.22	10.4	64.79
160	7.6	47.34	11.0	68.53
180	8.2	51.08	11.6	72.27
200	8.6	53.57	12.3	76.63
220	9.2	57.31	12.7	79.11
240	9.6	59.80	13.1	84.60
300	11.4	71.02	14.7	91.56
400	14.0	87.21	17.0	105.91
500	16.7	104.04	19.0	118.36
600	19.4	120.85	21.1	131.45
700	21.4	133.32	23.0	143.29
800	24.1	150.13	24.5	152.61
900	26.1	162.58	26.1	162.58
1000	28.1	175.05	28.1	175.05
1500	36.1	224.88	36.1	224.88
2000	43.9	273.48	43.9	273.48
2500	51.1	318.32	51.1	318.32
3000	57.8	360.07	57.8	360.07

¹⁾Unit rate of flow = Effective fixture units

5D.4.6.3.2 Probable simultaneous demand

The possibility that all water supply taps in any system in domestic and commercial use will draw water at the same time is extremely remote. Designing the water mains for the gross flow will result in bigger and uneconomical pipe mains and is not necessary. A probability study made by Hunter suggests the relationship shown in Fig. 5 and Table 5. In the absence of similar studies in MYANMAR, the curves based on Hunter's study may be followed. In making use of these curves, special allowances are made as follows:

- a) Demands for service sinks are ignored in calculating the total fixture demand.
- b) Demands of supply outlets such as hose connections and air conditioners through which water flows more or less continuously over a considerable length of time must be added to the probable flow rather than the fixture demand.
- c) Fixtures supplied with both hot and cold water exert reduced demands upon main hot water and cold water branches (not fixture branches).

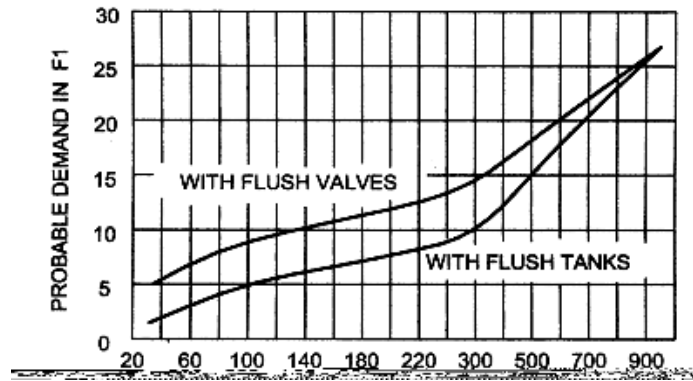

(EFU)

Figure 5 Graph For Portable Demand

5D.4.6.4 Pipe Size Computation

Commercially available standard sizes of pipes are only to be used against the sizes arrived at by actual design. Therefore, several empirical formulae are used, even though they give less accurate results. The Hazen and William's formula and the charts based on the same may be used without any risk of inaccuracy in view of the fact that the pipes normally to be used for water supply are of smaller sizes. Nomogram of Hazen and William's equation has been provided in Annex F.

5D.4.7 Distribution Systems in Multi-Storeyed Buildings

5D.4.7.1

There are four basic methods of distribution of water to multi-storeyed buildings.

- a) Direct supply from mains to ablutionary taps and kitchen with WCs and urinals supplied by overhead tanks.
- b) Direct Pumping Systems
- c) Hydro-Pneumatic Systems
- d) Overhead Tanks Distribution

5D.4.7.2 Direct Supply System

This system is adopted when adequate pressure is available round the clock at the topmost floor. With limited pressure available in most city mains, water from direct supply is normally

not available above two or three floors. For details of this system, reference may be made to good practice [9-1(5)] may be referred.

5D.4.7.3 Direct Pumping

5D.4.7.3.1

Water is pumped directly into the distribution system without the aid of any overhead tank, except for flushing purposes. The pumps are controlled by a pressure switch installed on the line. Normally a jockey pump of smaller capacity installed which meets the demand of water during low consumption and the main pump starts when the demand is greater. The start and stop operations are accomplished by a set of pressure switches are installed directly on the line. In some installation, a timer switch is installed to restrict the operating cycle of the pump.

5D.4.7.3.2

Direct pumping systems are suitable for buildings where a certain amount of constant use of water is always occurring. These buildings are all centrally air conditioned buildings for which a constant make up supply for air conditioning cooling towers is required.

5D.4.7.3.3

The system depends on a constant and reliable supply of power. Any failure in the power system would result in a breakdown in the water supply system,

5D.4.7.3.4

The system eliminates the requirements of overhead tanks for domestic purposes (except for flushing) and requires minimum space (*see* Fig. 6).

5D.4.7.4 Hydro-Pneumatic Systems

5D.4.7.4.1

Hydro-pneumatic system is a variation of direct pumping system. An air-tight pressure vessel is installed on the line to regulate the operation of the pumps. The vessel capacity shall be based on the cut-in and cut-out pressure of the pumping system depending upon allowable start/stops of the pumping system. As pumps operate, the incoming water in the vessel, compresses the air on top. When a predetermined pressure is reached in the vessel, a pressure switch installed on the vessel switches off the pumps. As water is drawn into the system, pressure falls into the vessel starting the pump at preset pressure. The air in the pressure tank slowly reduces the volume due to dissolution in water and leakages from pipe lines. An air compressor is also necessary to feed air into the vessel so as to maintain the required air-water ratio. The system shall have reliable power supply to avoid breakdown in the water supply.

5D.4.7.4.2

There is an alternate option of providing variable speed drive pumping system where a pump with a large variation in its pressure-discharge and speed of the pump is efficiently used to deliver water at rates of flow as required by the system by changing its speed by a varying its with the assistance of an electronic device which will reduce the rate of flow from speed of the motor from 960 rpm to 3 000 rpm. With this arrangement the same pump is able to deliver water as required at different times of the day. The system consumes energy in proportion to the work done and save considerable amount of power as compared to the fixed speed pumps used conventionally.

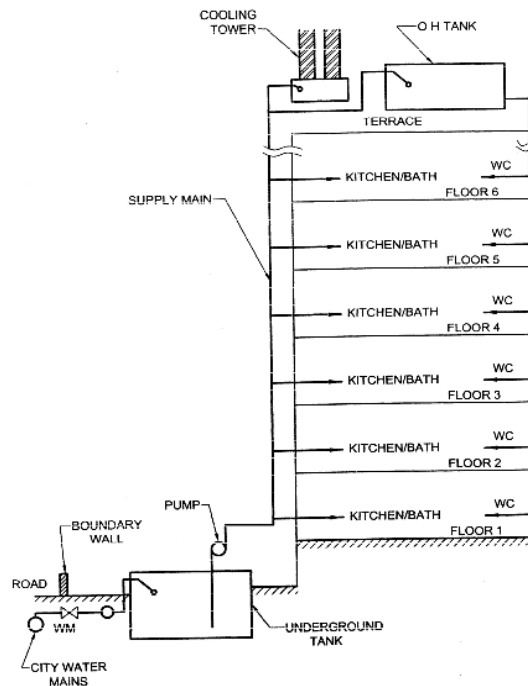

Figure 6 Direct Pumping System Applicable where There is Continuous Demand on System

5D.4.7.4.3

Hydro-pneumatic system generally eliminates the need for an over head tank and may supply water at a much higher pressure than available from overhead tanks particularly on the upper floors, resulting in even distribution of water at all floors (*see Fig. 7*).

5D.4.7.5 Overhead Tank Distribution

5D.4.7.5.1

This is the most common of the distribution systems adopted by various type of buildings.

5D.4.7.5.2

The system comprises pumping water to one or more overhead tanks placed at the top most location of the hydraulic zone.

5D.4.7.5.3

Water collected in the overhead tank is distributed to the various parts of the building by a set of pipes located generally on the terrace.

5D.4,7.5.4

Distribution is accomplished by providing down takes to various fixtures (*see Fig. 8*).

5D.4.8 General Requirements for Pipe Work

5D.4.8.1 Mains

The following principles shall apply for the mains:

- a) Service mains shall be of adequate size to give the required rate of flow.

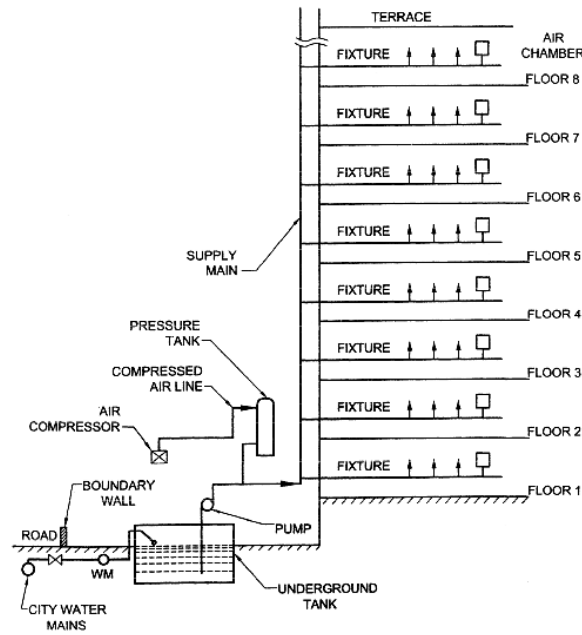

Figure 7 Hydro-Pneumatic System

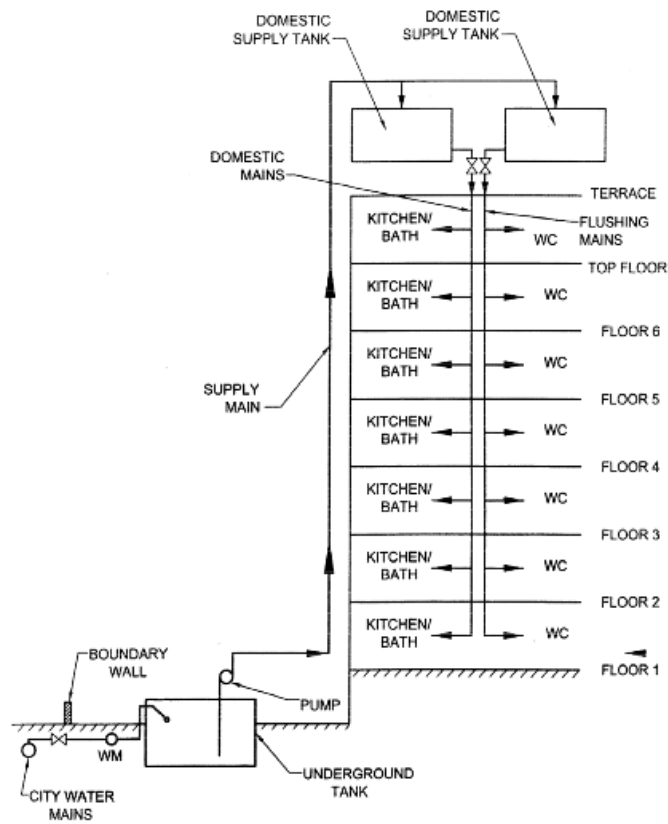

Figure 8 Overhead Tank Distribution

- a) The mains shall be divided into sections by the provisions of sluice valves and other valves so that water may be shut off for repairs.
- b) To avoid dead ends, the mains shall be arranged in a grid formation or in a network.
- c) Where dead ends are unavoidable, a hydrant shall be provided to act as a wash-out.
- d) The wash-out valve shall not discharge directly into a drain or sewer, or into a manhole or chamber directly connected to it; an effectively trapped chamber shall be interposed, into which the wash-out shall discharge.
- e) Air valves shall be provided at all summits, and wash-out at low points between summits.
- f) Mains need not be laid at unvarying gradients, but may follow the general contour of the ground. They shall, however, fall continuously towards the wash-out and rise towards the air valves. The gradient shall be such that there shall always be a positive pressure at every point under working conditions.
- g) The cover for the mains shall be at least 3 feet under roadways and 2 feet 6 inches in the case of footpaths. This cover shall be measured from the top of the pipe to the surface of the ground.
- h) The mains shall be located sufficiently away from other service lines like electric and telegraph cables to ensure safety and where the mains cannot be located away from such lines, suitable protective measures shall be accorded to the mains.

5D.4.8.2 Communication Pipes

- a) Every premises that is supplied with water by the Authority shall have its own separate communication pipe. In the case of a group or block of premises belonging to the same owner the same communication pipe may supply water to more than one premises with the prior permission of the Authority.
- b) The communication pipe between the water main and the stop-cock at the boundary of the premises shall be laid by the Authority.
- c) Connections up to 2 inches diameter may be made on the water main by means of screwed ferrules, provided the size of the connections does not exceed one-third the size of the water main. In all other cases, the connection shall be made by a T-branch off the water main.
- d) As far as practicable, the communication pipe and the underground service pipe shall be laid at right angles to the main and in approximately straight lines to facilitate location for repairs. It is also recommended that the communication pipe be laid in a pipe sleeve of larger dia. Made of non-corrosive material to protect the communication pipe.
- e) Every communication pipe shall have a stopcock and meter inserted in it. The waterway of each such fitting shall not be less than the internal sectional area of the communication pipe and the fittings shall be located within the premises at a conspicuous place accessible to the Authority which shall have exclusive control over it.

5D.4.8.3 Consumer Pipes

- a) No consumer pipe shall be laid in the premises to connect the communication pipe without the approval of the Authority.

PLUMBING SERVICES

- b) The consumer pipe within the premises shall be laid underground with a suitable cover to safeguard against damage from traffic and extremes of weather.
- c) To control the branch pipe to each separately occupied part of a building supplied by a common service pipe, a stop tap shall be fixed to minimize the interruption of the supply during repairs. All such stop valves shall be fixed in accessible positions and properly protected. To supply water for drinking or for culinary purposes, direct taps shall be provided on the branch pipes connected directly to the consumer pipe. In the case of multi-storeyed buildings, downtake taps shall be supplied from overhead tanks.
- d) Pumps shall not be allowed on the service pipe, as they cause a drop in pressure on the suction side, thereby affecting the supply to the adjoining properties. In cases where pumping is required, a properly protected storage tank of adequate capacity shall be provided to feed the pump.
- e) No direct boosting (by booster pumps) shall be allowed from the service pipes (communication and consumer pipes).
- f) Consumer pipes shall be so designed and constructed as to avoid air-locks. Draining taps shall be provided at the lowest points from which the piping shall rise continuously to draw-off taps.
- g) Consumer pipes shall be so designed as to reduce the production and transmission of noise as much as possible.
- h) Consumer pipes in roof spaces and unventilated air spaces under floors or in basements shall be protected against corrosion.
- i) Consumer pipes shall be so located that they are not unduly exposed to accidental damage and shall be fixed in such positions as to facilitate cleaning and avoid accumulations of dirt.
- j) All consumer pipes shall be so laid as to permit expansion and contraction or other movements.

5D.4.8.4 Prohibited Connections

- a) A service pipe shall not be connected into any distribution pipe; such connection may permit the backflow of water from a cistern into the service pipe, in certain circumstances, with consequent danger of contamination and depletion of storage capacity. It might also result in pipes and fittings being subjected to a pressure higher than that for which they are designed, and in flooding from overflowing cisterns.
- b) No pipe for conveyance or in connection with water supplied by the Authority shall communicate with any other receptacle used or capable of being used for conveyance other than water supplied by the Authority.
- c) Where storage tanks are provided, no person shall connect or be permitted to connect any service pipe with any distributing pipe.
- d) No service or supply pipe shall be connected directly to any water-closet or a urinal. All such supplies shall be from flushing cisterns which shall be supplied from storage tank.
- e) No service or supply pipe shall be connected directly to any hot water system or to any other apparatus used for heating other than through a feed cistern thereof.

5D.4.9 Jointing of Pipes**5D.4.9.1 Cast Iron Pipes**

Jointing may be done by any of the following methods:

- a) spigot and socket joints, or
- b) flanged joints in accordance with good practice [9-1(6)]. The lead shall conform to the accepted standards [9-1(7)].

5D.4.9.2 Steel Pipes

Plain-ended steel pipes may be jointed by welding. Electrically welded steel pipes shall be jointed in accordance with good practice [9-1(8)].

5D.4.9.3 Wrought Iron and Steel Screwed Pipes

Screwed wrought iron or steel piping may be jointed with screwed and socketed joints. Care shall be taken to remove any burr from the end of the pipes after screwing. A jointing compound approved by the Authority and containing no red lead composition shall be used. Screwed wrought iron or steel piping may also be jointed with screwed flanges.

5D.4.9.4 Asbestos Cement Pipes

Asbestos cement pipes may be jointed in accordance with good practice [9-1(9)].

5D.4.9.5 Copper Pipes

Copper pipes shall be jointed by internal solder ring joint, end-brazing joint or by use of compression fitting. The flux used shall be non-toxic and the solder used shall be lead free. The use of dezincification fittings shall be made in case of jointing of copper pipe and steel pipe.

5D.4.9.6 Concrete Pipes

Concrete pipes shall be jointed in accordance with good practice [9-1(10)].

5D.4.9.7 Polyethylene and Unplasticized PVC Pipes

Polyethylene and unplasticized PVC pipes shall be jointed in accordance with good practice [9-1(11)].

5D.4.10 Backflow Prevention**5D.4.10.1**

The installation shall be such that water delivered is not liable to become contaminated or that contamination of the public water supply does not occur.

5D.4.10.2

The various types of piping and mechanical devices acceptable for backflow protection are:

- a) Barometric loop,
- b) Air gap,
- c) Atmosphere vacuum breaker,
- d) Pressure vacuum breaker,
- e) Double check valve, and
- f) Reduced pressure backflow device.

5D.4.10.3 The installation shall not adversely affect drinking water:

- a) by materials in contact with the water being unsuitable for the purpose;
- b) as a result of backflow of water from water fittings, or water using appliances into pipework connected to mains or to other fittings and appliances;
- c) by cross-connection between pipes conveying water supplied by the water undertaker with pipes conveying water from some other source; and
- d) by stagnation, particularly at high temperatures.

5D.4.10.4

No pump or similar apparatus, the purpose of which is to increase the pressure in or rate of flow from a supply pipe or any fitting or appliance connected to a supply pipe, shall be connected unless the prior written permission of the water supplier has been obtained in each instance.

The use of such a pump or similar apparatus is likely to lead to pressure reduction in the upstream pipe work which, if significant, increase the risk of backflow from other fittings.

5D.4.10.5

The water shall not come in contact with unsuitable materials of construction.

5D.4.10.6

No pipe or fitting shall be laid in, on or through land fill, refuse, an ashpit, sewer, drain, cesspool or refuse chute, or any manhole connected with them.

5D.4.10.7

No pipe susceptible to deterioration by contact with any substance shall be laid or installed in a place where such deterioration is likely to occur. No pipe that is permeable to any contaminant shall be laid or installed in any position where permeation is likely to occur.

5D.4.10.8

If a liquid (other than water) is used in any type of heating primary circuit, which transfers heat to water for domestic use, the liquid shall be non-toxic and non-corrosive.

5D.4.10.9

A backflow prevention device shall be arranged or connected at or as near as practicable to each point of delivery and use of water. Appliances with built-in backflow prevention shall be capable of passing the test. All backflow prevention devices shall be installed so that they are accessible for examination, repair or replacement. Such devices shall be capable of being tested periodically by the Authority to ensure that the device is functioning efficiently and no backflow is occurring at any time.

5D.4.11 Conveyance and Distribution of Water Within the Premises

5D.4.11.1 Basic Principles

Wholesome water supply provided for drinking and culinary purposes shall not be liable to contamination from any less satisfactory water. There shall, therefore, be no cross-connection whatsoever between the distribution system for wholesome water and any pipe or fitting containing unwholesome water, or water liable to contamination, or of uncertain quality, or water which has been used for any other purpose. The provision of reflux or non-return valves or closed and sealed stop valves shall not be construed as a permissible substitute for complete absence of cross-connection.

5D.4.11.2

The design of the pipe work shall be such that there is no possibility of backflow towards the source of supply from any cistern or appliance, whether by siphonage or otherwise. Reflux non-return valves shall not be relied upon to prevent such backflow.

5D.4.11.3

Where a supply of less satisfactory water than wholesome water becomes inevitable as an alternative or is required to be mixed with the latter, it shall be delivered only into a cistern and by a pipe or fitting discharging into the air gap at a height above the top edge of the cistern equal to twice its nominal bore and in no case less than 6 inches. It is necessary to maintain a definite air gap in all appliances or taps used in water- closets.

5D.4.11.4

All pipe work shall be so designed, laid or fixed and maintained as to remain completely water-tight, thereby avoiding wastage, damage to property and the risk of contamination.

5D.4.11.5

No water supply line shall be laid or fixed so as to pass into or through any sewer, scour outlet or drain or any manhole connected therewith nor through any ash pit or manure pit or any material of such nature that is likely to cause undue deterioration of the pipe, except where it is unavoidable.

5D.4.11.5.1

Where the laying of any pipe through corrosive soil or previous material is unavoidable, the piping shall be properly protected from contact with such soil or material by being carried through an exterior cast iron tube or by some other suitable means as approved by the Authority. Any existing piping or fitting laid or fixed, which does not comply with the above requirements, shall be removed immediately by the consumer and relaid by him in conformity with the above requirements and to the satisfaction of the Authority.

5D.4.11.5.2

Where lines have to be laid in close proximity to electric cables or in corrosive soils, adequate precautions/protection should be taken to avoid corrosion.

5D.4.11.6

Underground piping shall be laid at such a depth that it is unlikely to be damaged by frost or traffic loads and vibrations. It shall not be laid in ground liable to subsidence, but where such ground cannot be avoided, special precautions shall be taken to avoid damage to the piping. Where piping has to be laid across recently disturbed ground, the ground shall be thoroughly consolidated so as to provide a continuous and even support.

5D.4.11.7

In designing and planning the layout of the pipe work, due attention shall be given to the maximum rate of discharge required, economy in labour and materials, protection against damage and corrosion, water hammer, protection from frost, if required, and to avoidance of airlocks, noise transmission and unsightly arrangement.

5D.4.11.8

To reduce frictional losses, piping shall be as smooth as possible inside. Methods of jointing shall be such as to avoid internal roughness and projection at the joints, whether of the jointing materials or otherwise.

5D.4.11.9

Change in diameter and in direction shall preferably be gradual rather than abrupt to avoid undue loss of head. No bend or curve in piping shall be made which is likely to materially diminish or alter the cross-section.

5D.4.11.10

No boiler for generating steam or closed boilers of any description or any machinery shall be supplied direct from a service or supply pipe. Every such boiler or machinery shall be supplied from a feed cistern.

5D.4.12 Laying of Mains and Pipes on Site

5D.4.12.1

The mains and pipes on site shall be laid in accordance with good practice [9-1(12)].

5D.4.12.2 Excavation and Refilling

The bottoms of the trench excavations shall be so prepared that the barrels of the pipes, when laid, are well bedded for their whole length on a firm surface and are true to line and gradient. In the refilling of trenches, the pipes shall be surrounded with fine selected material, well rammed so as to resist subsequent movement of the pipes. No stones shall be in contact with the pipes; when resting on rock, the pipes shall be bedded on fine-selected material or (especially where there is a steep gradient) on a layer of concrete.

5D.4.12.2.1

The pipes shall be carefully cleared of all foreign matter before being laid.

5D.4.12.3 Laying Underground Mains

Where there is a gradient, pipe laying shall proceed in 'uphill' direction to facilitate joint making.

5D.4.12.3.1

Anchor blocks shall be provided to withstand the hydraulic thrust.

5D.4.12.4

Iron surface boxes shall be provided to give access to valves and hydrants and shall be supported on concrete or brickwork which shall not be allowed to rest on pipes.

5D.4.12.5 Laying Service Pipes

5D.4.12.5.1

Service pipes shall be connected to the mains by means of right-hand screw down ferrule or T-branches. The ferrules shall conform to accepted standards [9-1(13)].

5D.4.12.5.2

Precaution against contamination of the mains shall be taken when making a connection and, where risk exists, the main shall be subsequently disinfected. The underground water

service pipe and the building sewer or drain shall be kept at a sufficient distance apart so as to prevent contamination of water. Water service pipes or any underground water pipes shall not be run or laid in the same trench as the drainage pipe. Where this is unavoidable, the following conditions shall be fulfilled:

- a) The bottom of the water service pipe, at all points, shall be at least 1 ft above the top of the sewer line at its highest point.
- b) The water service pipe shall be placed on a solid shelf excavated on one side of the common trench.
- c) The number of joints in the service pipe shall be kept to a minimum.
- d) The materials and joints of sewer and water service pipe shall be installed in such a manner and shall possess such necessary strength and durability as to prevent the escape of solids, liquids and gases there from under all known adverse conditions, such as corrosion strains due to temperature changes, settlement, vibrations and superimposed loads.

5D.4.12.5.3

The service pipe shall pass into or beneath the buildings at a depth of not less than 2 ft 6 in below the outside ground level and, at its point of entry through the structure, it shall be accommodated in a sleeve which shall have previously been solidly built into the wall of the structure. The space between the pipe and the sleeve shall be filled with bituminous or other suitable material for a minimum length of 6 inches at both ends.

5D.4.12.6 Pipes Laid Through Ducts, Chases, Notches or Holes

Ducts or chases in walls for piping shall be provided during the building of the walls. If they are cut into existing walls, they shall be finished sufficiently smooth and large enough for fixing the piping.

5D.4.12.6.1

Piping laid in notches or holes shall not be subjected to external pressure.

5D.4.12.7 Lagging of Pipes

Where lagged piping outside buildings is attached to walls, it shall be entirely covered all round with waterproof and fire insulating material and shall not be in direct contact with the wall. Where it passes through a wall, the lagging shall be continued throughout the thickness of the wall.

5D.4.13 Hot Water Supply Installations

5D.4.13.1 Design Consideration

5D.4.13.1.1 General

In electric water heating practice for domestic purposes, the accepted method is to use storage heaters in which water is steadily heated up to a predetermined temperature and stored until required for use. The heating by electricity of a large quantity of water, such as water required for a hot bath, within the time normally taken to run the water into the bath, requires a heater of too high a rating to be practicable in normal domes

5D.4.13.1.2

In modern hotels and apartment blocks and service apartments, centralized storage and distribution systems are adopted, where other energy sources such as oil, gas, solar panels, etc,

may be used for the generation of hot water as these options prove more economical and convenient in heating large volumes of water for storage.

5D.4.13.1.3

When water supplied to the buildings contain dissolved salts resulting in hardness of water, measures such as installation of water softening plants etc shall be taken to avoid formation of scales in the hot water installations.

5D.4.13.2 Storage Temperature

5D.4.13.2.1

The design of hot water supply system and its appliances shall be based on the temperatures at which water is normally required for the various uses, namely:

Scalding	150°F (65°C)
Sink	140°F (60°C)
Hot bath	110°F (43°C) as run, for use at 105°F (41°C)
Warm bath	98°F (37°C)
Tepid bath	85°F (29.5°C)

5D.4.13.2.2

In order to minimize the danger of scalding, precipitation of scale from hard water, standing heat losses, risk of steam formation and the possibility of damage to porcelain or other fittings and to surface finishes, a storage temperature of 140°F is recommended. If storage capacity is limited, a higher temperature up to 150°F may be adopted when soft water is used.

5D.4.13.3 Storage Capacity

The size of the storage vessel is governed by the maximum short time demand of the domestic premises. Depending on local conditions this shall be 10 gal to 15 gal at 140°F in a dwelling with a bath tub and 5 gal at 140°F for a shower or a tap (for bucket supply). The capacity of the storage vessel shall not be less than 20 percent in excess of the required maximum short time demand. In larger houses where a single hot water heater is intended to supply hot water to more than one bathroom or kitchen or both, the maximum short time demand shall be estimated and the capacity decided accordingly. Small electric or gas storage heaters of 3 gal to 5 gal capacity may be used to supply one or two points of draw off depending on the use of hot water. Values of volume of hot water required for a bath, when cold water is mixed with it are given in Table 6.

**Table 6: Volume of Hot Water Required for a Bath when cold water is Mixed with It
(Clause 4.13.3)**

Storage Temperature, °F	167	158	150	140	130	122
Percentage of hot water required	51	55	60	66	73	82.5
Quantity of hot water in gallons required for a 25 gallons bath	13	14	15	17	18.5	21

NOTE – Hot bath temperature at 106°F and cold water at about 41 to 42°F.

5D.4.13.4 Rate of Flow

With storage type installation, the recommended minimum rates of flow for different types of fixtures are given in Table 7.

Table 7: Rate of Hot Water Flow*(Clause 4.13.4)*

SI NO. (1)	Fixtures (2)	Rate of Flow gallons/ min (3)
i)	Bath tub	5
ii)	Kitchen	3
iii)	Wash basin	1.5
iv)	Shower (spray type)	1.5

5D.4.13.5 Design of Storage Vessel

Storage tanks shall be oblong or cylindrical in shape and shall be installed, preferably with the long side vertical in order to assist the effective stratification or 'layering' of hot or cold water. The ratio of height to width or diameter shall not be less than 2:1. An inlet baffle should preferably be fitted near the cold inflow pipe in order to spread the incoming cold water.

5D.4.13.6 Materials for Storage Vessel and Pipes

5D.4.13.6.1 Under no circumstances shall ungalvanized (black) mild steel pipes and fittings, such as sockets, bushes, etc, be used in any part of a hot water installation, including the cold feed pipe and the vent pipe. Materials resistant to the chemical action of water supplied shall be used in construction of vessels and pipes. Each installation shall be restricted to one type of metal only, such as all copper or all galvanized mild steel. When water supplied is known to have appreciable salt content, galvanized iron vessels and pipes shall not be used. However, it is advisable to avoid use of lead pipes in making connection to wash basins. Where required it is also advisable to use vessels lined internally with glass, stainless steel, etc.

5D.4.13.6.2

In general tinned copper and other metals such as other metals etc are suitable for most types of water. The suitability of galvanized mild steel for storage tanks depends upon the pH value of the water and the extent of its temporary hardness. For values of pH 7.2 or less, galvanized mild steel should not be used. For values of pH 7.3 and above, galvanized mild steel may be used provided the corresponding temporary hardness is not lower than those given below:

pH Value	Minimum Temporary Hardness Required (ppm)
7.3	210
7.4	150
7.5	140
7.6	110
7.7	90
7.8	80
7.9-8.5	70

5D.4.13.7 Location of Storage Vessel

The loss of heat increases in proportion to the length of pipe between the storage vessel and the hot water outlet since each time the water is drawn, the pipe fills with hot water which then cools. The storage vessel shall therefore be so placed that the pipe runs to the most frequently used outlets are as short as possible.

5D.4.13.8 Immersion Heater Installation

5D.4.13.8.1

If a domestic storage vessel is to be adopted to electric heating by the provision of an immersion heater and thermostat, the following precautions shall be observed:

- a) **Location of immersion heaters** — The immersion heater shall be mounted with its axis horizontal, except in the case of the circulation type which is normally mounted with its axis approximately vertical.
- b) In a tank with a flat bottom, a space of not less than 3in below the immersion heater and 5in below the cold feed connection shall be provided to allow for accumulation of sludge and scale, where it will not affect the working of the immersion heater.
- c) In a cylindrical storage vessel with inwardly dished bottom, the inlet pipe shall be so arranged that the incoming cold water is not deflected directly into the hot water zone. The lowest point of the immersion heater shall be 1inch above the centre line of the cold feed inlet, which, in turn, is usually 4inches above the cylinder rim.
- d) **Location of thermostat** — Where the thermostat does not form an integral part of the immersion heater, it shall be mounted with its axis horizontal, at least 2in away from and not lower than the immersion heater.
- e) **Dual heater installations** — If desired, the principle of the dual heater may be adopted. In this case, one heater and its thermostat shall be installed at a low level as indicated in (b) and (c). The second heater and its thermostat shall be similarly disposed in the upper half of the cylinder at a level depending on the reserve of hot water desired for ordinary domestic use. The bottom heater shall be under separate switch control.
- f) **Clearance around storage vessel** — Adequate clearance shall be provided between the tank and the cupboard, door or walls to allow convenient insertion and

adjustment of the immersion heater and thermostat and to give space for thermal insulation.

5D.4.13.8.2 Rating of Immersion Heaters

The rating of an immersion heater shall be determined according to the following factors:

- a) proposed hot water storage capacity (the maximum with cold water as indicated in **4.13.3** shall be taken into account),
- b) rate of utilization (draw off frequency),
- c) permissible recovery period, and
- d) inlet water temperature.

For details regarding rated input of water, refer to good practice [9-1(14)].

5D.4.13.9 Thermal Insulation

The hot water storage vessel and pipes shall be adequately insulated wherever necessary to minimize heat loss. The whole external surface of the storage vessel including the cover to the handhole, shall be provided with a covering equivalent to not less than 3 inches thickness of thermal insulating material having a conductivity of not more than $0.05 \text{ W}/(\text{m}^2 \cdot ^\circ\text{C})/\text{mm}$ at mean temperature of 122°F .

5D.4.13.10 Cold Water Supply to Heaters

5D.4.13.10.1

A storage water heater (pressure type) shall be fed from a cold water storage tank and under no circumstances connected directly to the water main, except the type which incorporates a feed tank with ball valves and overflow pipe arrangement (cistern type heaters) or non-pressure type heaters.

5D.4.13.10.2 Storage cisterns

5D.4.13.10.2.1

The storage capacity of a cold water tank shall be at least twice the capacity of the hot water heater. The capacity of the storage tank may, however, be 1.5 times when the number of heaters connected to one common tank exceeds 10.

5D.4.13.10.2.2

The storage tank for supply of cold water to hot water heaters shall be separate, if practicable. In the case of a common tank which also supplies cold water to the fixtures, this cold water supply connection shall be so arranged that 50 percent of the net capacity, worked out as in **4.13.10.2.1**, shall be available for supply to the hot water heaters.

5D.4.13.10.2.3

In the case of multi-storeyed buildings where a common overhead tank over the stair/lift well is generally installed, it is advisable to have one or more local tanks for supply to the hot water heaters. This arrangement shall help in reducing the length of the vent pipes (*see* Fig. 9).

5D.4.13.10.2.4

In tall multi-storeyed buildings where the static pressure increases with the height, the total static pressure on the hot water heaters on the lowest floor shall not exceed the rated working pressure of the hot water heater installed. Should the height of the building so require, additional tanks shall be provided on the intermediate floors to restrict the static head to permissible limits (*see* Fig. 10).

5D.4.13.10.2.5

As an alternative to the arrangements stated in 4.13.10.2.3 and 4.13.10.2.4 an individual storage tank in each flat may be provided for supply to hot water heaters (*see* Fig. 11).

5D.4.13.11 Cold Water Feed**5D.4.13.11.1**

The feed pipe connecting cold water tank with the hot water heater shall not be of less than $\frac{3}{4}$ inches bore and it shall leave the cold water tank at a point not less than 2 inches above the bottom of the tank and shall connect into the hot water heater near its bottom. The feed pipe shall not deliver cold water to any other connection, but into the hot water cylinders only.

5D.4.13.11.2

In the case of multi-storeyed buildings, a common cold water feed pipe may be installed, but each hot water heater shall be provided with a check valve (horizontal type check valve shall be preferred to vertical type for easy maintenance).

5D.4.13.11.3

Care shall be taken in installing the piping to prevent air locks in the piping and negative pressure in the hot water heater. Cold water feedpipe shall not be cross connected with any other source of supply under pressure (*see* Fig. 9).

5D.4.13.12 Hot Water Piping**5D.4.13.12.1 Expansion pipe or vent pipe****5D.4.13.12.1.1**

Each pressure type hot water heater or cylinder shall be provided with a vent pipe of not less than $\frac{3}{4}$ in bore. The vent pipe shall rise above the water line of the cold water tank by at least 6 in plus $\frac{1}{4}$ in for every 1 ft height of the water line above the bottom of the heater. The vent shall discharge at a level higher than the cold water tank and preferably in the cold water tank supplying the hot water heaters. Care shall be taken to ensure that any accidental discharge from the vent does not hurt or scald any passerby or persons in the vicinity.

5D.4.13.12.1.2

The vent pipe shall be connected to the highest point of the heater vessel and it shall not project downwards inside it, as otherwise air may be trapped inside, resulting in surging and consequent noises.

5D.4.13.12.1.3

At no point, after leaving the vessel, shall the vent pipe dip below the level of its connection with the vessel.

5D.4.13.12.1.4

A vent pipe may, however, be used for supply of hot water to any point between the cold water tank and the hot water heaters.

5D.4.13.12.1.5

The vent pipe shall not be provided with any valve or check valves.

5D.4.13.12.2 Hot water heaters**5D.4.13.12.2.1**

The common hot water delivery pipe shall leave the hot water heater near its top and shall be of not less than $\frac{3}{4}$ inch bore generally, not less than 1 inch bore if hot water taps are installed on the same floor as that on which the hot water heater is situated.

5D.4.13.12.2.2

Hot water taps shall be of such design as would cause the minimum friction. Alternatively, oversized tap may be provided, such as a $\frac{3}{4}$ inch tap on a $\frac{1}{2}$ inch pipe.

5D.4.13.12.2.3

The hot water distributing system shall be so designed as to ensure that the time lag between opening of the draw-off taps and discharge of hot water is reduced to the minimum to avoid wastage of an undue amount of water which may have cooled while standing in the pipes when the taps are closed. With this end in view, a secondary circulation system with flow and return pipes from the hot water tank shall be used where justified. Whether such a system is used or not, the length of pipe

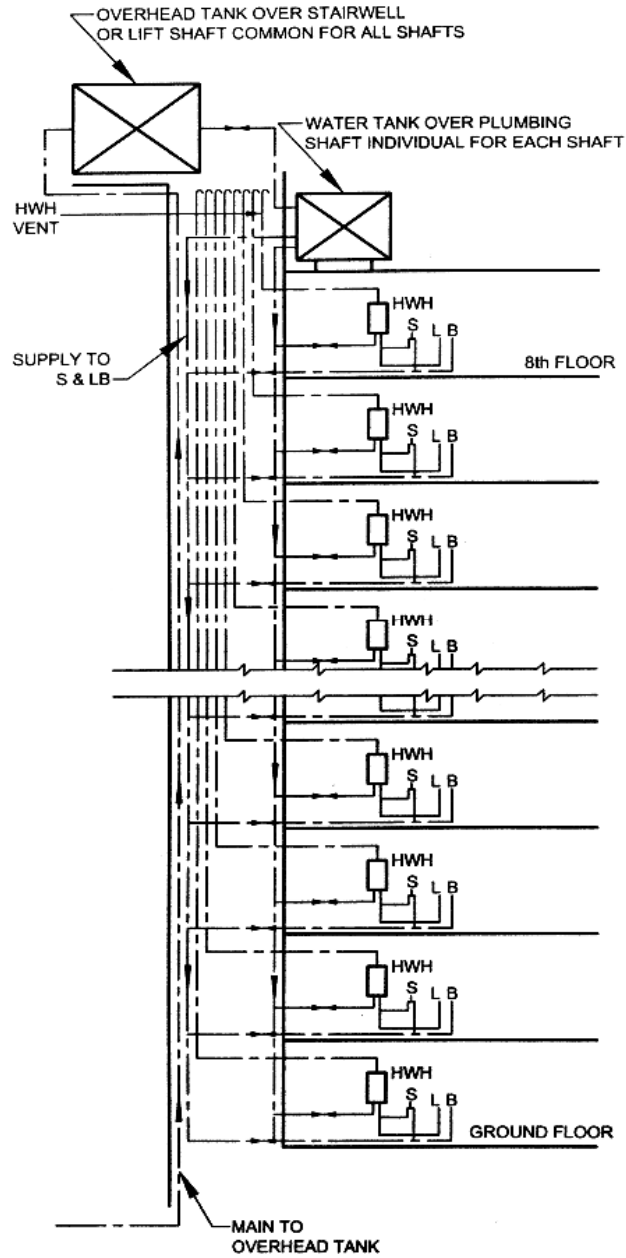

Figure 9 Installation For 8 – Storeyed Building

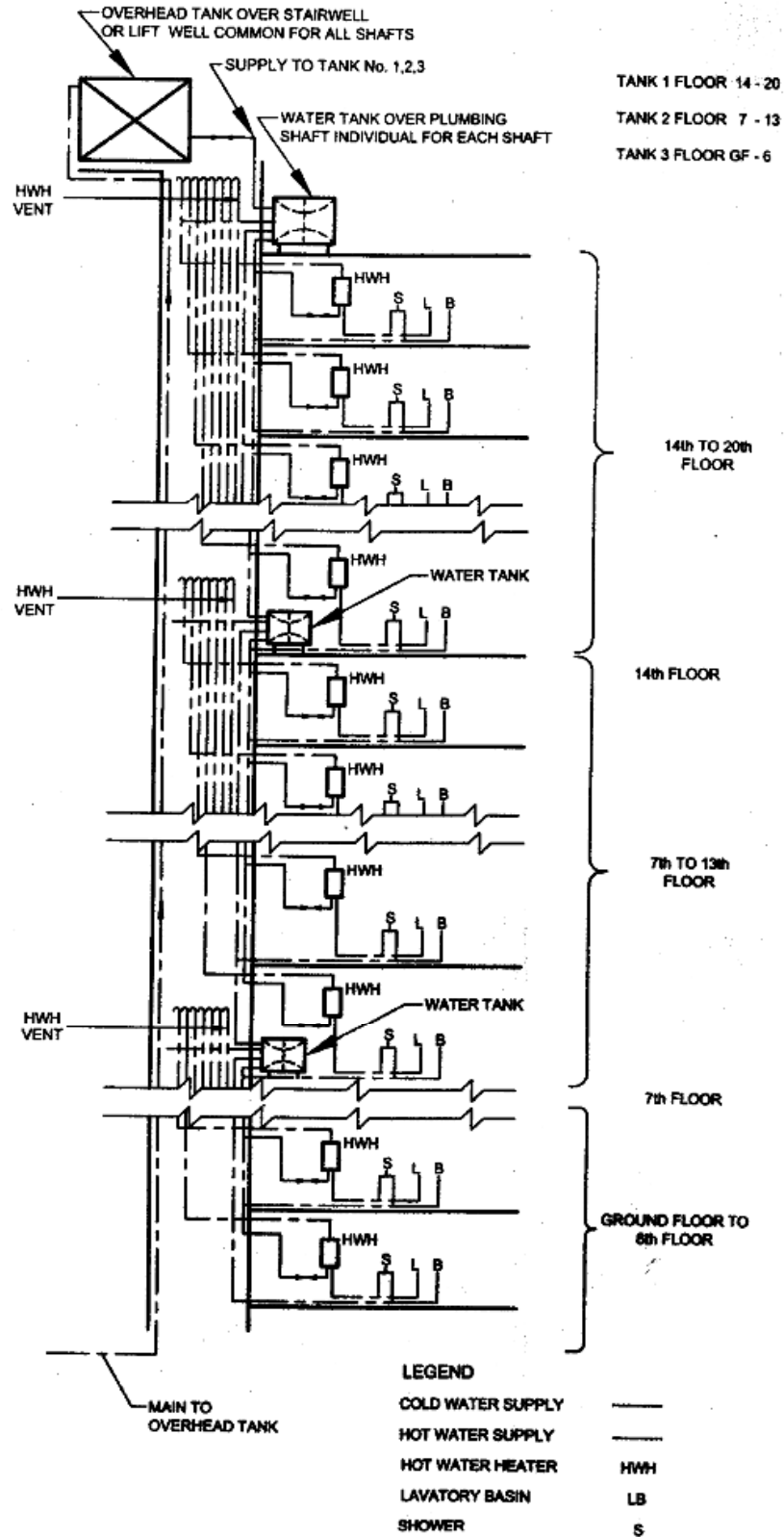

Figure 10 Installation For 20 – Storeyed Building

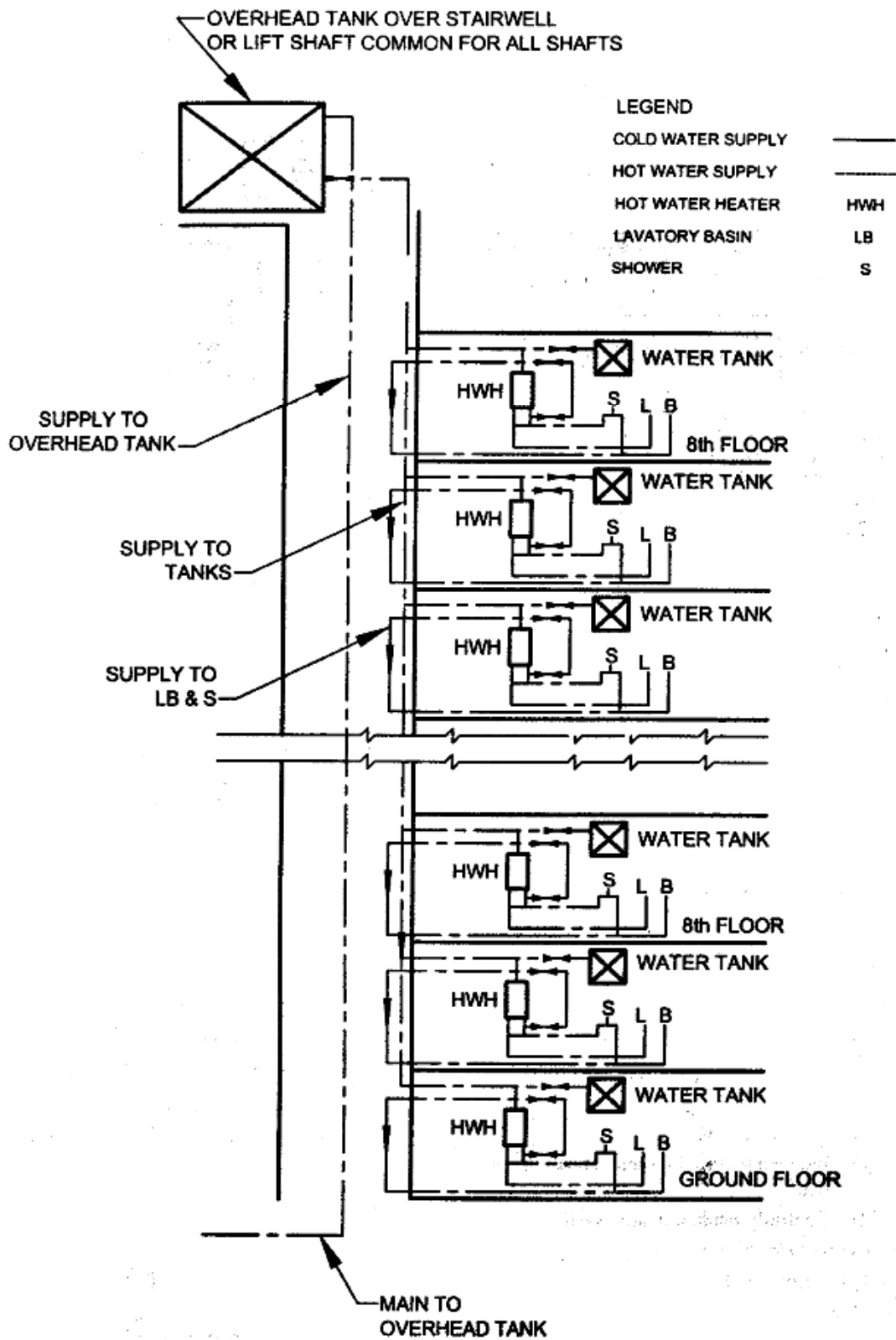

Figure 11 Installation For 8 – Storeyed Building with Individual Water Tanks

to a hot water draw-off tap, measured along the pipe from the tap to the hot water tank or the secondary circulation pipe, shall not exceed the lengths given in Table 8.

Table 8: Maximum Permissible Lengths of Hot Water Draw-off Pipes

(Clause 4.13.12.2.3)

SI NO. (1)	Largest Internal Diameter of Pipe (2)	Length, feet (3)
i)	Not exceeding ¾ inch	40'
ii)	Exceeding ¾ inch but not exceeding 1 inch	15'
iii)	Exceeding 1 inch	10'
NOTE – In the case of a composite pipe of different diameters, the largest diameter is to be taken into consideration for the purpose of this table.		

5D.4.13.12.2.4

Wherever mixing of hot and cold water is done by a mixing fitting, that is, hot and cold stop-cocks deliver to a common outlet of mixed water (that is, showers, basin or bath supply fittings), the pressure in the cold and hot water systems shall be equal. This can be achieved by connecting the cold water supply from an overhead tank at the same static height as the overhead tank supplying cold water to the hot water heaters. In case this is not possible, hot and cold water should be supplied to the fixtures by separate supply taps.

5D.4.13.13 Types of Hot Water Heaters

The various types of water heaters used for preparation of hot water are as follows:

- a) Electric Storage Heaters:
 - 1) Non-pressure or open outlet type,
 - 2) Pressure type,
 - 3) Cistern type, and
 - 4) Dual heater type.
- b) Gas Water Heaters:
 - 1) Instantaneous type, and
 - 2) Storage type.
- c) Solar Heating Systems:
 - 1) Independent roof mounted heating units, and
 - 2) Centrally banked heated system.
- d) Central Hot Water System
 - 1) Oil fired, and
 - 2) Gas fired.

5D.4.13.13.1

The quality and construction of the different types of hot water heaters shall be in accordance with good practice [9-1(15)].

5D.4.13.13.2 Typical arrangement of water heater is shown in Fig. 12.

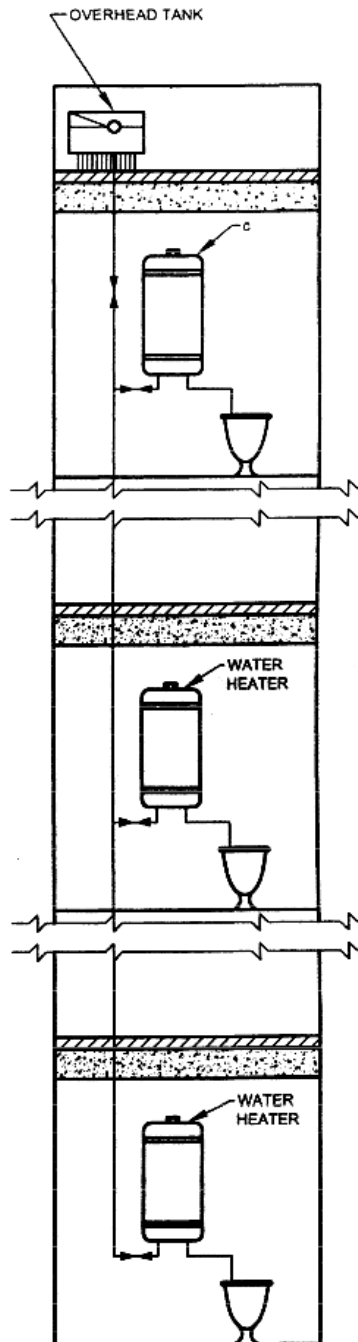

Figure 12 Non – Pressure Type Installation

5D.4.13.13.3

Requirements in regard to inspection and maintenance of hot water supply installations shall be in accordance with 4.14.1 to 4.14.4.

5D.4.14 Inspection and Testing**5D.4.14.1 Testing of Mains Before Commencing Work**

All pipes, fittings and appliances shall be inspected, before delivery at the site to see whether they conform to accepted standards. All pipes and fittings shall be inspected and tested by the manufacturers at their factory and shall comply with the requirements of this Section. They shall be tested hydraulically under a pressure equal to twice this maximum permissible working pressure or under such greater pressure as may be specified. The pipes and fittings shall be inspected on site before laying and shall be sounded to disclose cracks. Any defective items shall be clearly marked as rejected and forthwith removed from the site.

5D.4.14.2 Testing of Mains After Laying

After laying and jointing, the main shall be slowly and carefully charged with water by providing a 1 inch inlet with a stop-cock, so that all air is expelled from the main. The main is then allowed to stand full of water for a few days if time permits, and then tested under pressure. The test pressure shall be 168 ft or double the maximum working pressure, whichever is greater. The pressure shall be applied by means of a manually operated test pump, or, in the case of long mains or mains of a large diameter, by a power-driven test pump, provided the pump is not left unattended. In either case, due precaution shall be taken to ensure that the required test pressure is not exceeded. Pressure gauges shall be accurate and shall preferably have been recalibrated before the test. The pump having been stopped, the test pressure shall maintain itself without measurable loss for at least 5 min. The mains shall be tested in sections as the work of laying proceeds; it is an advantage to have the joints exposed for inspection during the testing. The open end of the main may be temporarily closed for testing under moderate pressure by fitting a water-tight expanding plug of which several types are available. The end of the main and the plug shall be secured by struts or otherwise, to resist the end thrust of the water pressure in the mains.

5D.4.14.2.1

If the section of the main tested terminates into a sluice valve, the wedge of the valve shall not be used to retain the water; instead the valve shall be temporarily fitted with a blank flange, or, in the case of a socketed valve, with a plug, and the wedge placed in the open position while testing. End support shall be given as in 4.14.2.

5D.4.14.3 Testing of Service Pipes and Fittings

When the service pipe is complete, it shall be slowly and carefully charged with water, allowing all air to escape, care being taken to avoid all shock or water hammer. The service pipe shall then be inspected under working conditions of pressure and flow. When all draw-offs taps are closed, the service pipe shall be absolutely water-tight. All piping, fittings and appliances shall be checked for satisfactory support, and protection from damage, corrosion and frost. Because of the possibility of damage in transit, cisterns shall be re-tested for water-tightness on arrival at the site, before fixing.

5D.4.14.4

In addition to the provisions given in 4.14.1, provisions given in 4.14.4.1 to 4.14.4.3 shall also apply to hot water supply installations in regard to inspection and testing.

5D.4.14.4.1 Testing of the system after installation

After the hot water system, including the hot water heaters, has been installed, it shall be carefully charged with water, so that all air is expelled from the system. The entire system shall then be hydraulically tested to a pressure of 168 ft or twice the working pressure, whichever is greater, for a period of at least half an hour after a steady state is reached. The entire installation shall then be inspected visually for leakages, and sweating. All defects found shall be rectified by removing and remaking the particular section. Caulking of threads, hammering and welding of leaking joints shall not be allowed.

5D.4.14.4.2 Hot water testing

After the system has been proved water-tight, the hot water heaters shall be commissioned by connecting the same to the electrical supply. The system shall then be observed for leakage in pipes due to expansion or overheating. The temperature of water at outlets shall be recorded. The thermostats of the appliances shall be checked and adjusted to temperatures specified in 5D.4.13.2.1.

5D.4.14.4.3 Electrical connection

For relevant provisions regarding general and safety requirements for household and similar electrical appliances, reference may be made to good practice [9-1(14)]. The metal work of the water heating appliances and installation other than current carrying parts shall be bonded and earthed in conformity with the good practice [9-1(14)]. It should be noted that screwing of an immersion heater into a tank or cylinder cannot be relied upon to effect a low resistance earth connection, a satisfactory separate earthing of heater should be effected.

5D.4.15 Cleaning and Disinfection of the Supply System**5D.4.15.1**

All water mains communications pipes, service pipes and pipes used for distribution of water for domestic purposes shall be thoroughly and efficiently disinfected before being taken into use and also after every major repair. The method of disinfection shall be subject to the approval of the Authority. The pipes shall also be periodically cleaned at intervals, depending upon the quality of water, communication pipes and the storage cisterns shall be thoroughly cleaned at least once every year in order to remove any suspended impurities that may have settled in the pipes or the tanks.

5D.4.15.2 Disinfection of Storage Tanks and Downtake Distribution Pipes

The storage tanks and pipes shall first be filled with water and thoroughly flushed out. The storage tank shall then be filled with water again and a disinfecting chemical containing chlorine added gradually while the tanks are being filled, to ensure thorough mixing. Sufficient quantities of chemicals shall be used to give the water a dose of 50 parts of chlorine to one million parts of water. If ordinary bleaching powder is used, the proportions will be 0.33 lb of powder to 220 gallons of water. The powder shall be mixed with water to a creamy consistency before being added to the water in the storage tank. When the storage tank is full, the supply shall be stopped and all the taps on the distributing pipes opened successively working progressively away from the storage tank. Each tap shall be closed when the water discharged begins to smell of chlorine. The storage tank shall then be topped up with water from the supply pipe and with more disinfecting chemical in the recommended proportions. The storage tank and pipes shall then remain charged for at least 3 hours. Finally, the tank and pipes shall be thoroughly flushed out before any water is used for domestic purposes.

5D.4.16 Water Supply Systems in High Altitudes and/ or Sub-zero Temperature Regions**5D.4.16.1 Selection and Source**

In general, the site selected for a water source shall be such as to minimize the length of transmission line so as to reduce the inspection and upkeep. Attempt shall be made, where feasible, to locate the source near the discharge of waste heat, such as of power plants provided it does not affect the potability of water.

5D.4.16.2 Pumping Installation

Pump and pumping machinery shall be housed inside well-insulated chambers. Where necessary, arrangements shall be made for heating the inside of pump houses. Pump houses, as far as possible, should be built directly above the water intake structures.

5D.4.16.3 Protection of Storage Water and Treatment

Where ambient temperatures are so low as to cause danger of freezing, proper housing, insulation and protection shall be provided for all processes and equipment. If necessary, means shall be provided for proper heating of the enclosure.

5D.4.16.4 Transmission and Distribution

Freezing of the buried pipe may be avoided primarily by laying the pipe below the level of the frost line; well consolidated bedding of clean earth or sand, under, around or over the pipe should be provided. For the efficient operation and design of transmission and distribution work, the available heat in the water shall be economically utilized and controlled. If the heat which is naturally present in water is made equate to satisfy heat losses from the system, the water shall be warmed. Where economically feasible, certain faucets on the distribution system may be kept in a slightly dripping condition so as to keep the fluid in motion and thus prevent is freezing. If found unsuitable for drinking purposes, such water may be used for heating purposes. Heat losses shall be reduced by insulation, if necessary. Any material that will catch, absorb or hold moisture shall not be used for insulation purposes. Adequate number of break pressure water tanks and air release valves shall be provided in the distribution system.

NOTE — The level of frost line is generally found to be between 3 ft and 4 ft below ground level in the northern regions of MYANMAR, wherever freezing occurs.

5D.4.16.4.1 Materials for pipes

Distribution pipes shall be made of any of the following materials conforming to Part 5 'Building Materials':

- a) high density polyethylene pipes,
- b) asbestos cement pipes,
- c) galvanized iron pipes,
- d) cast iron pipes, and
- e) unplasticized PVC pipes (where it is laid before frost line).

5D.4.16.4.2 Materials for insulation of pipes

The normal practice in MYANMAR is to surround the pipe with straw, grass or jute wrapped over with gunny and painted with bitumen; alternatively, other materials, like 85 percent magnesia, glass wool, etc, or with the approval of the Authority may also be used.

5D.4.16.4.3 Distribution methods

Distribution by barrels or tank trucks shall be employed, where the water requirements are temporary and small. Utmost care shall be exercised for preventing the water from being contaminated by maintaining a residual of disinfecting agent at all times. Hoses, pails and the tank shall be kept free from dust and filth during all period of operation. Where winter temperatures are low, making frost penetration depths greater during the winter, and where adequate facilities for heating the water in the distribution system do not exist, the use of tank trucks or barrels for delivery of water shall be considered only for cold weather; during the warm weather, piping system for seasonal use may be supplemented.

5D.4.16.4.4

In the conventional distribution system involving the use of a network of pipelines requiring no auxiliary heat, it is essential that the pipelines are buried well below the frost line. Adequate facilities for draining the pipelines shall be provided where there is a danger of frost.

5D.4.16.4.5 House service connections

House service connections shall be kept operative by the use of adequate insulation at exposed places extending below the frost line. Figure 10 shows a typical arrangement for providing insulation for house service connections.

5D.4.16.5

For detailed information on planning and designing water supply system peculiar to high altitudes and/or sub-zero temperature regions of the country, reference may be made to good practice [9-1(16)].

5D.4.17 Guidelines to Maintenance**5D.4.17.1**

Storage tanks shall be regularly inspected and shall be cleaned out periodically, if necessary. Tanks showing signs of corrosion shall be emptied, thoroughly wire brushed to remove loose material (but not scraped), cleaned and coated with suitable bituminous compositions or other suitable anti-corrosive material not liable to impart taste or odor or otherwise contaminate the water. Before cleaning the cistern, the outlets shall be plugged to prevent debris from entering the pipes. Tanks shall be examined for metal wastage and water tightness after cleaning.

5D.4.17.2

Record drawings showing pipe layout and valve positions shall be kept up to date and inspection undertaken to ensure that any maintenance work has not introduced cross-connections or any other undesirable feature. Any addition or alterations to the systems shall be duly recorded from time-to-time.

5D.4.17.3

Any temporary attachment fixed to a tap or outlet shall never be left in such a position that back-siphonage of polluted water may occur into the supply system.

5D.4.17.4

All valves shall periodically be operated to maintain free movement of the working parts.

5D.4.17.5

All taps and ball valves shall be watertight, glands shall be made good, washers shall be replaced and the mechanism of spring operated taps and ball valves shall be repaired where required.

5D.4.17.6

All overflow pipes shall be examined and kept free from obstructions.

5D.4.17.7

The electrical installation shall be checked for earth continuity and any defects or deficiencies corrected in the case of hot water supply installations.

5D.5 DRAINAGE AND SANITATION**5D.5.1 Types of Sanitary Appliances****5D.5.1.1 Soil Appliances****5D.5.1.1.1 Water-closet**

It shall essentially consist of a closet consisting of a bowl to receive excretory matter, trap and a flushing apparatus. It is recommended to provide ablation tap adjacent to the water-closet, preferably on right hand side wall. The various types/style of water-closets may be:

- a) Squatting Indian type water closet,
- b) Washdown type water closet,
- c) Siphonic washdown type water closet, and
- d) Universal or Anglo-Indian water closet.

5D.5.1.1.2 Bidet

It is provided with hot and cold water connection. The bidet outlet should essentially connect to soil pipe in a two-pipe system.

5D.5.1.1.3 Urinal

It is a soil appliance and is connected to soil pipe after a suitable trap. Urinal should have adequate provision of flushing apparatus. The various types/style of urinal may be:

- a) Bowl type urinal: Flat back or Angle back,
- b) Slab (single) type urinal,
- c) Stall (single) type urinal,
- d) Squatting plate type urinal, and
- e) Syphon jet urinal with integral trap.

5D.5.1.1.4 Slop sink and bed pan sink

Slop sink is a large sink of square shape. The appliance is used in hospitals installed in the nurse's station, operation theatres and similar locations for disposal of excreta and other foul waste for washing bed pans and urine bottles/pans. It is provided with a flushing mechanism.

5D.5.1.2 Waste Appliances**5D.5.1.2.1 Washbasin**

It is of one piece construction having a combined overflow and preferably should have soap holding recess or recesses that should properly drain into the bowl. Each basin shall have circular waste hole through which the liquid content of the basin shall drain.

5D.5.1.2.2 Wash-trough

It is a linear trough for simultaneous use by number of persons.

5D.5.1.2.3 Sink

It is used in kitchen and laboratory for the purpose of cleaning utensils/apparatus and also serve the purpose of providing water for general usage. The sink may be made with or without overflow arrangement. The sink shall be of one piece construction including combined over flow, where provided. The sink shall have a circular waste hole into which the interiors of the sink shall drain.

5D.5.1.2.4 Bath tub

Bath tub may be of enamelled steel, cast iron, gel- coated, glass fibre reinforced plastic or may be cast *in-situ*. It shall be stable, comfortable, easy to get in and out, water tight, with anti-skid base, and easy to install and maintain. The bath tub shall be fitted with overflow and waste pipe of nominal diameter of not less than 1.25 inches and 1.5 inches respectively.

5D.5.1.2.5 Drinking fountain

It is a bowl fitted with a push button tap and a water bubbler or a tap with a swan neck outlet fitting. It has a waste fitting, a trap and is connected to the waste pipe.

5D.5.1.3

The requirements of various soil appliances and waste appliances shall be in accordance with accepted standards [9-1(17)].

5D.5.2 Drainage and Sanitation Requirements**5D.5.2.1 General**

There should be at least one water tap and arrangement for drainage in the vicinity of each water-closet or group of water-closet in all the buildings.

5D.5.2.2

Each family dwelling unit on premises (abutting on a sewer or with a private sewage disposal system) shall have, at least, one water-closet and one kitchen type sink. A bath or shower shall also be installed to meet the basic requirements of sanitation and personal hygiene.

5D.5.2.3

All other structures for human occupancy or use on premises, abutting on a sewer or with a private sewage-disposal system, shall have adequate sanitary facilities, but in no case less than one water-closet and one other fixture for cleaning purposes.

5D.5.2.4 For Residences

5D.5.2.4.1

Dwelling with individual convenience shall have at least the following fitments:

- a) One bathroom provided with a tap and a floor trap;
- b) One water-closet with flushing apparatus with an ablution tap; and
- c) One tap with a floor trap or a sink in kitchen or wash place.

5D.5.2.4.1.1

Where only one water-closet is provided in a dwelling, the bath and water-closet *desirably* shall be separately accommodated.

NOTE — Water-closets, unless indicated otherwise, shall be of Indian style (squatting type).

5D.5.2.4.2

Dwellings without individual conveniences shall have the following fitments:

- a) One water tap with floor trap in each tenement,
- b) One water-closet with flushing apparatus and one ablution tap bath for every two tenements, and
- c) One bath with water tap and floor trap for every two tenements.

5D.5.2.5 For Buildings Other than Residences**5D.5.2.5.1**

The requirements for fitments for drainage and sanitation in the case of buildings other than residences shall be in accordance with Table 9 to Table 22. The following shall be, in addition, taken into consideration:

- a) The figures shown are based upon one (1) fixture being the minimum required for the number of persons indicated or part thereof.

Table 9 Office Buildings
(Clause 5.2.5.1)

Sl No	Fixtures	Public Toilets		Staff Toilets	
		Male	Females	Male	Females
(1)	(2)	(3)	(4)	(5)	(6)
i)	Executive Rooms and Conference Halls in Office Buildings Toilet suite comprising one WC, one washbasin (with optional shower stall if building is used round the clock at user's option) Pantry optional as per user requirement	Unit could be common for Male/Female or separate depending on the number of user of each facility		For individual officer rooms	
ii)	Main Office Toilets for Staff and Visitors				
	a) Water-closets	1 per 25	1 per 15	1 per 25	1 per 15
	b) Ablution tap with each water-closet	← 1 in each water-closet →			
	c) Urinals	Nil up to 6 1 for 7-20 2 for 21-45 3 for 46-70 4 for 71-100 101-200 Over 200	—	Nil up to 6	—
	Add @ 3% for				
	Add @ 2.5 %				
	d) Washbasins	1 per 25	1 per 25	1 per 25	1 per 25
	e) Drinking water fountain	1 per 100	1 per 100	1 per 100	1 per 100
	f) Cleaner's sink	← 1 per floor →			

Table 10 Factories
(Clause 5.2.5.1)

Sl No	Fixtures	Offices/Visitors		Workers	
		Male	Female	Male	Female
(1)	(2)	(3)	(4)	(5)	(6)
i)	Water-closets (Workers & Staff)	1 for up to 25 2 for 16-35 3 for 36-65 4 for 66-100	1 for up to 15 2 for 16-25 3 for 26-40 4 for 41-57 5 for 58-77 6 for 78-100	1 for up to 15 2 for 16-35 3 for 36-65 4 for 66-100	1 for up to 12 2 for 13-25 3 for 26-40 4 for 41-57 5 for 58-77 6 for 78-100
	For persons 101-200 add	3%	5%	3%	5%
	For persons over 200 add	2.5%	4%	2.50%	4%
ii)	Ablution tap	1 in each water-closet	1 in each water-closet	1 in each water-closet	1 in each water-closet
iii)	Urinals	Nil up to 6 1 for 7-20 2 for 21-45 3 for 46-70 4 for 71-100	—	Nil up to 6 1 for 7-20 2 for 21-45 3 for 46-70 4 for 71-100	—
	For persons 101-200 add	3%		3%	
	For persons over 200 add	2.50%		2.50%	
iv)	Washbasins	1 per 25 or part thereof	1 per 25 or part thereof	1 per 25 or part thereof	1 per 25 or part thereof
	Washbasins in rows or troughs and taps spaced 750 mm c/c				
v)	Drinking water fountain	1 per every 100 or part thereof with minimum one on each floor		1 per every 100 or part thereof with minimum one on each floor	
vi)	Cleaner's sink	1 on each floor	1 on each floor	1 on each floor	1 on each floor
vii)	Showers/Bathing rooms	← As per trade requirements →			
viii)	Emergency shower and eye wash fountain	—	—	1 per every shop floor per 500 persons	

NOTE — For factories requiring workers to be engaged in dirty and dangerous operations or requiring them to be extremely clean and sanitized conditions additional and separate (if required so) toilet facilities and if required by applicable Industrial and Safety Laws and the *Factories Act* must be provided in consultation with the user.

Table 11 Cinema, Multiplex Cinema, Concerts and Convention Halls, Theatres
(Clause 5.2.5.1)

Sl No.	Fixtures	Public		Staff	
		Male	Female	Male	Female
(1)	(2)	(3)	(4)	(5)	(6)
i)	Water-closets	1 per 100 up to 400 Over 400 add at 1 per 250 or part thereof	3 per 100 up to 200 Over 200 add at 2 per 100 or part thereof	1 for up to 15	1 for up to 12
ii)	Ablution tap	1 in each water-closet	1 in each water-closet	1 in each water-closet	1 in each water-closet
1 water tap with draining arrangements shall be provided for every 50 persons or part thereof in the vicinity of water-closets and urinals					
iii)	Urinals	1 per 25 or part thereof	—	Nil up to 6 1 for 7-20 2 for 21-45	—
iv)	Washbasins	1 per 200 or part thereof		1 for up to 15 2 for 16-35	1 for up to 12 2 for 13-25
v)	Drinking water fountain	←————— 1 per 100 persons or part thereof —————→			
vi)	Cleaner's sink	←————— 1 per floor —————→			
vii)	Showers/Bathing rooms	←————— As per trade requirements —————→			

NOTES

1 Some WCs may be European style if desired.

2 Male population may be assumed as two-third and female population as one-third.

Table 12 Art Galleries, Libraries and Museums
(Clause 5.2.5.1)

Sl No.	Fixtures	Public		Staff	
		Male	Female	Male	Female
(1)	(2)	(3)	(4)	(5)	(6)
i)	Water-closets	1 per 200 up to 400 Over 400 add at 1 per 250 or part thereof	1 per 100 up to 200 Over 200 add at 1 per 150 or part thereof	1 for up to 15 2 for 16-35	1 for up to 12 2 for 13-25
ii)	Ablution tap	One in each water-closet	One in each water-closet	One in each water-closet	One in each water-closet
1 water tap with draining arrangements shall be provided for every 50 persons or part thereof in the vicinity of water-closets and urinals					
iii)	Urinals	1 per 50	—	Nil up to 6 1 per 7 to 20 2 per 21-45	—
iv)	Washbasins	1 for every 200 or part thereof. For over 400, add at 1 per 250 persons or part thereof	1 for every 200 or part thereof. For over 200, add at 1 per 150 persons or part thereof	1 for up to 15 2 for 16-35	1 for up to 12 2 for 13-25
v)	Drinking water fountain	←————— 1 per 100 persons or part thereof —————→			
vi)	Cleaner's sink	←————— 1 per floor, Min —————→			
vii)	Showers/Bathing rooms	←————— As per requirements —————→			

NOTES

1 Some WC's may be European style if desired.

2 Male population may be assumed as two-third and female population as one-third.

Table 19 Schools and Educational Institutions
(Clause 5.2.5.1)

Sl No.	Fixtures	Nursery School	Non-Residential		Residential	
			Boys	Girls	Boys	Girls
(1)	(2)	(3)	(4)	(5)	(6)	(7)
i)	Water-closets	1 per 15 pupils or part thereof	1 per 40 pupils or part thereof	1 per 25 pupils or part thereof	1 per 8 pupils or part thereof	1 per 6 pupils or part thereof
ii)	Ablution tap	One in each water-closet 1 water tap with draining arrangements shall be provided for every 50 persons or part thereof in the vicinity of water-closets and urinals	One in each water-closet	One in each water-closet	One in each water-closet	One in each water-closet
iii)	Urinals	—	1 per 20 pupils or part thereof	—	1 per 25 pupils or part thereof	—
iv)	Washbasins	1 per 15 pupils or part thereof	1 per 60 pupils or part thereof	1 per 40 pupils or part thereof	1 per 8 pupils or part thereof	1 per 6 pupils or part thereof
v)	Bath/Showers	1 per 40 pupils or part thereof	—	—	1 per 8 pupils or part thereof	1 per 6 pupils or part thereof
vi)	Drinking water fountain or taps	1 per 50 pupils or part thereof	1 per 50 pupils or part thereof	1 per 50 pupils or part thereof	1 per 50 pupils or part thereof	1 per 50 pupils or part thereof
vii)	Cleaner's sink					1 per each floor

NOTES

1 Some WC's may be European style if desired.

2 For teaching staff, the schedule of fixtures to be provided shall be the same as in case of office building.

Table 20 Hostels
(Clause 5.2.5.1)

Sl No.	Fixtures	Resident		Non-Resident		Visitor/Common Rooms	
		Males	Females	Males	Females	Males	Females
(1)	(2)	(3)	(4)	(5)	(6)	(7)	(8)
i)	Water-closets	1 per 8 or part thereof	1 per 6 or part thereof	1 for up to 15 2 for 16-35 3 for 36-65 4 for 66-100	1 for up to 12 2 for 13-25 3 for 26-40 4 for 41-57 5 for 58-77 6 for 78-100	1 per 100 up to 400 Over 400 add at 1 per 250	2 per 100 up to 200 Over 200 add at 1 per 100
ii)	Ablution tap	One in each water-closet 1 water tap with draining arrangements shall be provided for every 50 persons or part thereof in the vicinity of water-closets and urinals	One in each water-closet	One in each water-closet	One in each water-closet	One in each water-closet	One in each water-closet
iii)	Urinals	1 per 25 or part thereof	—	Nil up to 6 1 for 7-20 2 for 21-45 3 for 46-70 4 for 71-100	—	1 per 50 or part thereof	—
iv)	Washbasins	1 per 8 persons or part thereof	1 per 6 persons or part thereof	1 for up to 15 2 for 16-35 3 for 36-65 4 for 66-100	1 for up to 12 2 for 13-25 3 for 26-40 4 for 41-57 5 for 58-77 6 for 78-100	1 per WC/Urinal	1 per WC
v)	Bath/Showers	1 per 8 persons or part thereof	1 per 6 persons or part thereof	—	—	—	—
vi)	Cleaner's sink						1 per each floor

NOTE — Some WC's may be European style if desired.

↳ separate provision shall be made for staff and workers.

- b) Building categories not included in the tables shall be considered separately by the Authority.
- c) Drinking fountains shall not be installed in the toilets.
- d) Where there is the danger of exposure to skin contamination with poisonous, infectious or irritating material, washbasin with eye wash jet and an emergency shower located in an area accessible at all times with the passage/ right of way suitable for access to a wheel chair, shall be provided.
- e) When applying the provision of these tables for providing the number of fixtures, consideration shall be given to the accessibility of the fixtures. Using purely numerical basis may not result in an installation suited to the need of a specific building. For example, schools should be provided with toilet facilities on each floor. Similarly toilet facilities shall be provided for temporary workmen employed in any establishment according to the needs; and in any case one WC and one washbasin shall be provided.
- f) All buildings used for human habitation for dwelling, work, occupation, medical care or any purpose detailed in the various tables, abutting a public sewer or a private sewage disposal system, shall be provided with minimum sanitary facilities as per the schedule in the tables. In case the disposal facilities are not available, they shall be provided as a part of the building design for ensuring high standards of sanitary conditions in accordance with this section.
- g) Workplaces where creches are provided, they shall be provided with one WC for 10 persons or part thereof, one washbasin for 15 persons or part thereof, one kitchen sink with floor trap for preparing food/milk preparations. The sink provided shall with a drinking water tap.
- h) In all types of buildings, individual toilets and pantry should be provided for executives, and for meeting/seminar/conference rooms, etc as per the user requirement.
- j) Where food is consumed indoors, water stations may be provided in place of drinking water fountains.

5D.5.3 Materials, Fittings and Appliances

5D.5.3.1 Standards for Materials, Fittings and Sanitary Appliances

All materials, fittings and sanitary appliances shall conform to Part 5 'Building Materials'.

5D.5.3.2 Choice of Material for Pipes

5D.5.3.2.1 Salt glazed stoneware pipe

For all sewers and drains in all soils, except where supports are required as in made-up ground, glazed stoneware pipe shall be used as far as possible in preference to other types of pipes. These pipes are particularly suitable where acid effluents or acid subsoil conditions are likely to be encountered. Salt glazed stoneware pipes shall conform to accepted standards [9-1(18)].

5D.5.3.2.2 Cement concrete pipes

When properly ventilated, cement concrete pipes with spigot and socket or collar joints present an alternative to glazed stoneware sewers of over 6 inches diameter. These shall not be used to carry acid effluents or sewage under conditions favourable for the production

of hydrogen sulphide and shall not be laid in those subsoils that are likely to affect adversely the quality or strength of concrete. Owing to the longer lengths of pipes available, the joints would be lesser in the case of cements concrete pipes. These pipes may be used for surface water drains in all diameters. Cement concrete pipes shall conform to accepted standards [9-1(19)].

5D.5.3.2.3 Cast iron pipes

5D.5.3.2.3.1

These pipes shall be used in the following situation:

- a) in bed or unstable ground where soil movement is expected;
- b) in-made-up or tipped ground;
- c) to provide for increased strength where a sewer is laid at insufficient depth, where it is exposed or where it has to be carried on piers or above ground;
- d) under buildings and where pipes are suspended in basements and like situations;
- e) in reaches where the velocity is more than 9 ft/s; and
- f) for crossings of watercourses.

NOTE — In difficult foundation condition such as in the case of black cotton soil, the cast iron pipes shall be used only when suitable supporting arrangements are made.

5D.5.3.2.3.2

It shall be noted that cast iron pipes even when given a protective paint are liable to severe external corrosion in certain soils; among such soils are:

- a) soils permeated by peaty waters; and
- b) soils in which the sub-soil contains appreciable concentrations of sulphates. Local experiences shall be ascertained before cast iron pipes are used where corrosive soil conditions are suspected. Where so used, suitable measures for the protection of the pipes may be resorted to as an adequate safeguard.

5D.5.3.2.3.3

Cast iron pipes shall conform to accepted standards [9-1(20)].

5D.5.3.2.4 Asbestos cement pipes

Asbestos cement pipes are commonly used for house drainage systems and they shall conform to accepted standards [9-1(21)]. They are not recommended for underground situations. However, asbestos cement pressure pipes conforming to accepted standards [9-1(21)] may be used in underground situations also, provided they are not subject to heavy superimposed loads. These shall not be used to carry acid effluents or sewage under conditions favourable for the production of hydrogen sulphide and shall not be laid in those sub-soils which are likely to affect adversely the quality or strength of asbestos cement pipes. Where so desired, the life of asbestos cement pipes may be increased by lining inside of the pipe with suitable coatings like epoxy/polyester resins etc.

5D.5.3.2.6 PVC pipes

Unplasticized PVC pipes may be used for drainage purposes; however, where hot water discharge is anticipated, the wall thickness shall be minimum 0.1 inches irrespective of the size and flow load.

PVC and HDPE pipes shall conform to accepted standards [9-1(23)].

NOTE — Where possible, high density polyethylene pipes (HDPE) and PVC pipes may be used for drainage and sanitation purposes, depending upon the suitability.

5D.5.4 Preliminary Data for Design**5D.5.4.1 General**

Before the drainage system for a building or group of buildings is designed and constructed, accurate information regarding the site conditions is essential. This information may vary with the individual scheme but shall, in general, be covered by the following:

- a) Site Plan (see 5D.3.3.2).
- b) Drainage Plan (see 5D.3.3.3).
- c) Use — A description of the use for which the building is intended and periods of occupation in order that peak discharges may be estimated;
- d) Nature of Waste — While dealing with sewage from domestic premises, special problems under this head may not arise; however, note shall be taken of any possibility of trade effluents being discharged into the pipes at a future date;
- e) Outlet Connection — The availability of sewers or other outlets;
- f) Cover — The depth (below ground) of the proposed sewers and drains and the nature and weight of the traffic on the ground above them;
- g) Sub-soil Condition:
 - 1) The approximate level of the subsoil water, and any available records of flood levels shall be ascertained, as also the depth of the water table relative to all sewer connections, unless it is known to be considerably below the level of the latter;
 - 2) In the case of deep manholes, this information will influence largely the type of construction to be adopted. The probable safe bearing capacity of the subsoil at invert level may be ascertained in the case of a deep manhole.
 - 3) Where work of any magnitude is to be undertaken, trial pits or boreholes shall be put at intervals along the line of the proposed sewer or drain and the data therefrom tabulated, together with any information available from previous works carried out in the vicinity. In general the information derived from trial pits is more reliable than that derived from boreholes. For a long length of sewer or drain, information derived from a few trial pits at carefully chosen points may be supplemented by that obtained from number of intermediate boreholes. Much useful information is often obtained economically and quickly by the use of a soil auger;
 - 4) The positions of trial pits or boreholes shall be shown on the plans, together with sections showing the strata found and the dates on which water levels are recorded.
 - a) **Location of Other Services** — The position, depth and size of all other pipes, mains, cables, or other services, in the vicinity of the proposed work, may be ascertained from the Authority, if necessary;

(b) Reinstatement of Surfaces — Information about the requirements of the highway authority is necessary where any part of the sewer or drain is to be taken under a highway. Those responsible for the sewer or drain shall be also responsible for the maintenance of the surface until permanently reinstated. The written consent of the highway authority to break up the surface and arrangement as to the charges thereof and the method and type of surface reinstatement shall always be obtained before any work is commenced;

(c) Diversion and Control of Traffic

In cases where sewers cross roads or footpaths, cooperation shall be maintained with the police and Authorities regarding the control and diversion of vehicular and/or pedestrian traffic as may be necessary. Access to properties along the road shall always be maintained and adequate notice shall be given to the occupiers of any shops or business premises, particularly if obstruction is likely;

During the period of diversion, necessary danger lights, red flags, diversion boards, caution boards, watchmen, etc, shall be provided as required by the Authority;

(d) Way-leaves (Easements) — The individual or authority carrying out the work is responsible for negotiating way-leaves where the sewer crosses land in other ownership. The full extend and conditions of such way-leaves shall be made known to the contractor and his employees, and prior notice of commencement of excavation shall always be given to the owners concerned, and cooperation with them shall be maintained at all stages, where sewers run across fields or open ground, the exact location of manholes shall be shown on way-leaves or easement plans. The right of access to manhole covers and the right to maintain the sewer shall be specifically included in any way-leave or easement arrangements which may be made with the owner of the land; and

(e) Damage to Buildings and Structures — When sewer trenches have to be excavated near buildings or walls a joint inspection with the owners of the property shall be made to establish whether any damage or cracks exist before starting the work, and a properly authenticated survey and record of the condition of buildings likely to be affected shall be made. Tell tales may be placed across outside cracks and dated, and kept under observation. Un-retouched photographs taken by an independent photographer may provide useful evidence.

5D.5.4.2 Drainage into a Public Sewer

Where public sewerage is available, the following information is particularly necessary and may be obtained from the Authority:

- (a) the position of the public sewer or sewers in relation to the proposed buildings;
- (b) the invert level of the public sewer;
- (c) the system on which the public sewers are designed (combined, separate or partially separate), the lowest level at which connection may be made to it, and the Authority in which it is vested;
- (d) the material of construction and condition of the sewer if connection is not to be made by the Authority;

- (e) the extent to which surcharge in the sewer may influence the drainage scheme;
- (f) whether the connection to the public sewer is made, or any part of the drain laid, by the Authority, or whether the owner is responsible for this work; if the latter, whether the Authority imposes any special conditions;
- (g) whether an intercepting trap is required by the Authority on the drain near the boundary of the curtilage; and
- (h) where manholes are constructed under roads, the approval of the Highway Authority for the type of cover to be fitted shall be obtained.

5D.5.4.3 Other Methods of Disposal of Sewage

5D.5.4.3.1

Where discharge into a public sewer is not possible, the drainage of the building shall be on a separate system. Foul water shall be disposed of by adequate treatment approved by the Authority on the site. The effluent from the plant shall be discharged into a natural watercourse or on the surface of the ground or disposed of sub-soil dispersion preferably draining to a suitable outlet channel.

5D.5.4.3.2

In the case of dilution into a natural stream course, the quality of the effluent shall conform and the requirements of the Authority controlling the prevention of pollution of streams.

5D.5.4.3.3

In the case of sub-soil dispersion, the requirements of the Authority for water supply shall be observed to avoid any possible pollution of local water supplies or wells.

5D.5.4.3.4

The general sub-soil water level and the subsoil conditions shall be ascertained, including the absorptive capacity of the soil.

5D.5.4.3.5

A sub-soil dispersion is not desirable near a building or in such positions that the ground below the foundations is likely to be affected.

5D.5.4.3.6

Under the separate system, drainage of standard the building shall be done through septic tanks of different sizes or by stabilization ponds or by any other methods approved by the Authority.

For detailed information on the design and construction of septic tanks and waste stabilization ponds, reference may be made to good practice [9-2(24)].

5D.5.4.4 Disposal of Surface and Sub-soil Waters

All information which may influence the choice of methods of disposal of surface and/or sub-soil waters shall be obtained. In the absence of surface water drainage system, and if practicable and permissible, disposal into a natural water-course or soakaway may be adopted. The location and flood levels of the water course as also the requirements of the Authority controlling the river or the waterway shall be ascertained.

5D.5.5 Planning and Design Considerations

5D.5.5.1 Aim

The efficient disposal of foul and surface water from a building is of great importance to public health and is an essential part of the construction of the building. In designing a drainage system for an individual building or a housing colony, the aim shall be to provide a system of self-cleaning conduits for the conveyance of foul, waste, surface or subsurface waters and for the removal of such wastes speedily and efficiently to a sewer or other outlet without risk of nuisance and hazard to health.

5D.5.5.1.1

To achieve this aim a drainage system shall satisfy the following requirements:

- a) rapid and efficient removal of liquid wastes without leakage;
- b) prevention of access of foul gases to the building and provision for their escape from the system.
- c) adequate and easy access for clearing obstructions;
- d) prevention of undue external or internal corrosion, or erosion of joints and protection of materials of construction; and
- e) avoidance of air locks, siphonage, proneness to obstruction, deposit and damage.

5D.5.5.1.2

The realization of an economical drainage system is added by compact grouping of fittings in both horizontal and vertical directions. This implies that if care is taken and ingenuity brought into play when designing the original building or buildings to be drained, it is possible to group the sanitary fittings and other equipment requiring drainage; both in vertical and horizontal planes, as to simplify the drainage system and make it most economical.

5D.5.5.1.3

Efficient and an economical plumbing system can be achieved by planning the toilets in compact grouping with the layout of the bathrooms and observing the following guidelines:

- a) Placing of plumbing fixtures around an easily accessible pipe shaft; in high rise buildings the pipe shafts may have to be within the building envelope and easy provision for access panels and doors should be planned in advance, in such cases.
- b) Adopting repetitive layout of toilets in the horizontal and vertical directions.
- c) Avoiding any conflict with the reinforced cement concrete structure by avoiding embedding pipes in it, avoiding pipe crossings in beams, columns and major structural elements.
- d) Identifying open terraces and areas subject to ingress of rainwater directly or indirectly and providing for location of inlets at each level for down takes for disposal at ground levels.
- e) Avoiding crossing of services of individual property through property of other owners.
- f) Planning to avoid accumulation of rain water or any backflow from sewers particularly in planned low elevation areas in a building.

5D.5.5.2 Layout

5D.5.5.2.1 General

Rain-water should preferably be dealt separately from sewage and sullage. Sewage and sullage shall be connected to sewers. However, storm water from the courtyard may be connected to the sewer where it is not possible to drain otherwise; after obtaining permission of the Authority.

5D.5.5.2.2 Additional Requirement

The following requirements are suggested to be considered in the design of drainage system:

- a) The layout shall be as simple and direct as practicable.
- b) The pipes should be laid in straight lines, as far as possible, in both vertical and horizontal planes.
- c) Anything that is likely to cause irregularity of flow, as abrupt changes of direction, shall be avoided.
- d) The pipes should be non-absorbent, durable, smooth in bore and of adequate strength.
- e) The pipes should be adequately supported without restricting movement.
- f) Drains should be well ventilated, to prevent the accumulation of foul gases and fluctuation of air pressure within the pipe, which could lead to unsealing of gully or water-closet traps.
- g) All the parts of the drainage system should be accessible for feasibility of inspection and practical maintenance.
- h) No bends and junctions whatsoever shall be permitted in sewers except at manholes and inspection chambers.
- i) Sewer drain shall be laid for self-cleaning velocity of 2.5 ft/s and generally should not flow more than half-full.
- j) Pipes crossing in walls and floors shall be through mild steel sleeves of diameter leaving an annular space of 0.2 inches around the outer diameter of the pipe crossing the wall.
- k) Pipes should not be laid close to building foundation.
- l) Pipes should not pass near large trees because of possibility of damage by the roots.
- m) Branch connections should be swept in the direction of flow.
- n) Sewer pipes should be at least 3 ft below road and at least 2 ft below fields and gardens.
- o) Pipes should not pass under a building unless absolutely necessary.
- p) Where it is necessary to lay pipes under a building, the following conditions shall be observed:
 - 1) Pipes shall be cast iron pressure pipe as per good practice [9-2(20)];
 - 2) The pipe shall be laid in straight line and at uniform gradient;

- 3) Means of access in form of manholes/ inspection chamber shall be provided at *each* end, immediately outside the building; and
- 4) In case the pipe or any part of it is laid above the natural surface of the ground, it shall be laid on concrete supports, the bottom of which goes at least 6 inches below the ground surface.

NOTE — It is desirable that pipe/drains should not be taken through a living room or kitchen and shall preferably be taken under a staircase room or passage.

- q) Consideration shall be given to alternative layouts so as to ensure that the most economical and practical solution is adopted. The possibility of alterations shall be avoided by exercising due care and forethought.

5D.5.5.2.3 Protection against vermin and dirt

The installation of sanitary fittings shall not introduce crevices which are not possible to inspect and clean readily.

Pipes, if not embedded, shall be run well clear of the wall. Holes through walls to taken pipes shall be made good on both sides to prevent entry of insects. Materials used for embedding pipes shall be rodent-proof. Passage of rodents from room-to-room or from floor- to-floor shall be prevented by suitable sealing. The intermediate lengths of ducts and chases shall be capable of easy inspection. Any unused drains, sewers, etc, shall be demolished or filled in to keep them free from rodents.

All pipe shafts shall be plastered before any pipes are installed in the shaft. This will provide a smooth surface and prevent location for survival of insects and vermins.

5D.5.5.2.4 Choice of plumbing system

In selecting one or more of the type of piping systems, the building and the layout of toilets; relationship with other services; acceptability to the Authority; and any special requirements of users, shall be studied.

a) Two-pipe system

- 1) This system is ideal when the location of toilets and stacks for the WCs and waste fittings is not uniform or repetitive.
- 2) In large buildings and houses with open ground and gardens the sullage water from the waste system can be usefully utilized for gardening and agriculture.
- 3) In larger and multi-storied buildings, the sullage is treated within the building for re-use as makeup water for cooling towers for air conditioning system and is also used for flushing water-closets provided it has absolutely no connection with any water supply line, tank or system used for domestic and drinking supply.

b) One-pipe system

- 1) This system is suitable for buildings where the toilet layouts and the shafts are repetitive. It requires less space, and is economical.
- 2) Continuous flow of water in the pipe from waste appliances makes it less prone to blockage and makes the system more efficient.

- 3) The system eliminates the need for a gully trap which requires constant cleaning.
- 4) The system is ideal when the main pipes run at the ceiling of the lowest floor or in a service floor. Two-pipe system may present space and crossing problems which this system eliminates.

(c) Single stack system

- 1) The single stack system (without any vent pipe) is ideal when the toilet layouts are repetitive and there is less space for pipes on the wall.
- 2) In any system so selected there should be not more than two toilet connections per floor.
- 3) The system requires minimum 4 inches diameter stack for a maximum of five floors in a building.
- 4) All the safeguards for the use of this system given in **5.5.2.4.1** shall be complied with.

d) Single stack system (partially ventilated)

- 1) The system and the applicable safeguards under this system are the same as for single stack system. The prime modification is to connect the waste appliances, such as wash basin, bath tub or sink to a floor trap.
- 2) For detailed information regarding design and installation of soil, waste and ventilating pipes, reference may be made to good practice [9-2(25)].

5D.5.5.2.4.1 Safeguards for single stack system

- a) as far as practicable, the fixtures on a floor shall be connected to stack in order of increasing discharge rate in the downward direction;
- b) the vertical distance between the waste branch (from floor trap or from the individual appliance) and the soil branch connection, when soil pipe is connected to stack above the waste pipe, shall be not less than 8 inches;
- c) depth of water seal traps from different fixtures shall be as follows:

Water closets 2 inches

Floor traps 2 inches

Other fixtures directly connected to the stack.

- 1) Where attached to branch waste pipes of 3 inches dia or more 1.5 inches
- 2) Where attached to branch waste pipes of less than 3 inches dia 3 inches

NOTE — When connection is made through floor trap, no separate seals are required for individual fixtures.

- d) branches and stacks which receive discharges from WC pans should not be less than 4 inches, except where the outlet from the siphonic water closet is 3¼ inches, in which case a branch pipe of 3¼ inches may be used. For outlet of floor traps 3 inches dia pipes may be used;

- e) the horizontal branch distance for fixtures from stack, bend(s) at the foot of stack to avoid back pressure as well as vertical distance between the lowest connection and the invert of drain shall be as shown in Fig. 2A; and
- f) for tall buildings, ground floor appliances are recommended to be connected directly to manhole/inspection chamber.

5D.5.5.3 Drainage (Soil, Waste and Ventilating) Pipes

5D.5.5.3.1 General considerations

5D.5.5.3.1.1

Drainage pipes shall be kept clear of all other services. Provisions shall be made during the construction of the building for the entry of the drainage pipes. In most cases this may be done conveniently by building sleeves or conduit pipes into or under the structure in appropriate positions. This will facilitate the installation and maintenance of the services.

5D.5.5.3.1.2

Horizontal drainage piping should be so routed as not to pass over any equipment or fixture where leakage from the line could possibly cause damage or contamination. Drainage piping shall never pass over switch-gear or other electrical equipment. If it is impossible to avoid these areas and piping must run in these locations, then a pan or drain tray should be installed below the pipe to collect any leakage or condensation. A drain line should run from this pan to a convenient floor drain or service sink.

5D.5.5.3.1.3

All vertical soil, waste, ventilating and anti- siphonage pipes shall be covered on top with a copper or heavily galvanized iron wire dome or cast iron terminal guards. All cast iron pipes, which are to be painted periodically, shall be fixed to give a minimum clearance of 2 inches clear from the finished surface of the wall by means of a suitable clamps.

NOTE — Asbestos cement cowls may be used in case asbestos cement pipes are used as soil pipes.

5D.5.5.3.1.4

Drainage pipes shall be carried to a height above the buildings as specified for ventilating pipe (*see* 5D. 5.5.3.4).

5D.5.5.3.2 Soil pipes

A soil pipe, conveying to a drain, any solid or liquid filth, shall be circular and shall have a minimum diameter of 4 inches.

5D.5.5.3.2.1

Except where it is impracticable, the soil pipe shall be situated outside the building or in suitably designed pipe shafts and shall be continued upwards without diminution of its diameter, and (except where it is unavoidable) without any bend or angle, to such a height and position as to afford by means of its open end a safe outlet for foul air. The position of the open end with its covering shall be such as to comply with the conditions set out in 5D.5.5.3.4 relating to ventilating pipe. Even if the pipes are laid externally, the soil pipes shall not be permitted on a wall abutting a street unless the

Authority is satisfied that it is unavoidable. Where shafts for pipes are provided, the cross-sectional area of the shaft shall be suitable to allow free and unhampered access to the pipes and fittings proposed to be installed in the shaft. However in no case cross-section area of the shaft shall be less than a square of one meter side. All pipe shafts shall be provided with an access door at ground level and facilities for ventilation.

5D.5.5.3.2.2

Soil pipes, whether insider or outside the building, shall not be connected with any rainwater pipe and there shall not be any trap in such soil pipe or between it and any drain with which it is connected.

5D.5.5.3.2.3

Soil pipes shall preferably be of cast iron. Asbestos cement building pipes may also be used as soil pipes only above ground level.

5D.5.5.3.2.4

The soil pipe shall be provided with heel rest bend which shall rest on sound footing, if terminating at firm ground level. When the stack is terminating at the ceiling of a floor, the bend shall be provided with sufficient structural support to cater for the stack dead weight and the thrust developed from the falling soil/waste. Vertical stack shall be fixed at least 2 inches clear of the finished surface of the wall by means of a suitable clamps of approved type.

5D.5.5.3.3 Waste pipes

Every pipe in a building for carrying off the waste or overflow water from every bath, washbasin or sink to a drain shall be of 1¼ inches to 2 inches diameter, and shall be trapped immediately beneath such washbasins or sink by an efficient siphon trap with adequate means for inspection and cleaning. Such traps shall be ventilated into the external air whenever such ventilation is necessary to preserve the seal of the trap. Waste pipes, traps, etc, shall be constructed of iron, lead, brass, stoneware, asbestos cement or other approved material. The overflow pipe from washbasin, sinks, etc, shall be connected with the waste pipe immediately above the trap. Vertical pipes carrying off waste water shall have a minimum diameter of 3 inches.

NOTE — Whenever washbasins and sinks have in-built overflow arrangements, there is no need to provide overflow pipes in such cases.

5D.5.5.3.3.1

Every pipe in a building for carrying off waste water to a drain shall be taken through an external wall of the building by the shortest practicable line, and shall discharge below the grating or surface box of the chamber but above the *inlet* of a properly trapped gully. The waste pipe shall be continued upwards without any diminution in its diameter and (except when unavoidable) without any bend or angle to such a height and position as to afford by means of the open end of the waste pipe, a safe outlet for foul air, the position of the open end and its covering being such as to comply with the conditions.

5D.5.5.3.3.2

Except where it is impracticable, the common waste pipe shall be situated outside the building and shall be continued upwards without diminution of its diameter (except where it is unavoidable) without any bend or angle being formed to such a height and

position as to avoid by means of the open end a safe outlet for foul air, the position of the open end and the covering throat being such as to comply with the conditions set out in 5.5.3.4 relating to ventilating pipe.

5D.5.5.3.3

If the waste pipe is of cast iron, it shall be firmly attached 2 inches clear of the finished surface of the wall by means of a suitable clamps or with properly fixed holder bats or equally suitable and efficient means.

5D.5.5.3.4 Ventilating pipes

Ventilating pipes should be so installed that water cannot be retained in them. They should be fixed vertically. Whenever possible, horizontal runs should be avoided. Ventilating pipe shall be carried to such a height and in such a position as to afford by means of the open end of such pipe or vent shaft, a safe outlet for foul air with the least possible nuisance.

5D.5.5.3.4.1

The upper end of the main ventilating pipe may be continued to the open air above roof level as a separate pipe, or it may join the MSP and/or MWP above the floor level of the highest appliance. Its lower end may be carried down to join the drain, at a point where air relief may always be maintained.

5D.5.5.3.4.2

Branch ventilating pipes should be connected to the top of the BSP and BWP between 3 inches and 1 ft 6 in from the crown of the trap.

5D.5.5.3.4.3

The ventilating pipe shall always be taken to a point 2 ft above the level of the eaves or flat roof or terrace parapet whichever is higher or the top of any window within a horizontal distance of 5 ft. The least dimension shall be taken as a minimum and local conditions shall be taken into account. The upper end of every ventilating pipe shall be protected by means of a cowl.

5D.5.5.3.4.4

In case the adjoining building is taller, the ventilating pipe shall be carried higher than the roof of the adjacent building, wherever it is possible.

5D.5.5.3.4.5

The building drain intended for carrying waste water and sewage from a building shall be provided with at least one ventilating pipe situated as near as practicable to the building and as far away as possible from the point at which the drain empties into the sewer or other carrier.

5D.5.5.3.4.6 Size of ventilating pipe

- (a) The building drain ventilating pipe shall be of not less than 3 inches diameter when, however, it is used as MSP or MWP. The upper portion, which does not carry discharges, shall not be of lesser diameter than the remaining portion;
- (b) The diameter of the main ventilating pipe in any case should not be less than 2 inches;

- (c) A branch ventilating pipe on a waste pipe in both one-and two-pipe systems shall be of not less than two-thirds the diameter of the branch waste ventilated pipe; subject to a minimum of 1 inch; and
- (d) A branch ventilating pipe on a soil pipe in both one-and two-pipe systems shall be not less than 1¼ inches in diameter.

5D.5.5.3.5 Design of drainage pipes

5D.5.5.3.5.1 Estimation of maximum flow of sewer

a) Simultaneously discharge flow

- (1) The maximum flow in a building drain or a stack depends on the probable maximum number of simultaneously discharging appliances. For the calculation of this peak flow certain loading factors have been assigned to appliances in terms of fixture units, considering their probability and frequency of use. These fixture unit values are given in Table 23.
- (2) For any fixtures not covered under Table 23, Table 24 may be referred to for deciding their fixture unit rating depending on their drain or trap size,
- (3) From Tables 23 and 24, the total load on any pipe in terms of fixtures units may be calculated knowing the number and type of appliances connected to this pipe.
- (4) For converting the total load in fixture units to the peak flow in gallons per minute, Fig. 13 is to be used.
- (5) The maximum number of fixture units that are permissible various recommended pipe size in the drainage system are given in Tables 25 and 26.
- (6) Results should be checked to see that the soil, waste and building sewer pipes are not reduced in diameter in the direction of flow. Where appliances are to be added in fixture, these should be taken into account in assessing the pipe sizes by using the fixture units given in Tables 23 and 24,

- b) **Maximum discharge flow** — The maximum rate of discharge flow shall be taken as thrice the average rate, allowance being made in addition for any exceptional peak discharges. A good average rule is to allow⁷ for a flow of liquid wastes from buildings at the rate of 3 litres per minute per 10 persons.

5D.5.5.3.5.2 Gradients

5D.5.5.3.5.2.1

The discharge of water through a domestic drain is intermittent and limited in quantity and, therefore, small accumulations of solid matter are liable to form in the drains between the building and the public sewer. There is usually a gradual shifting of these deposits as discharges take place. Gradients should be sufficient to prevent these temporary accumulations building up and blocking the drains.

Table 23 Fixture Units for Different Sanitary Appliances or Groups

(Clause 5D.5.5.3.5.1)

SI No. (1)	Type of Fixture (2)	Fixture Unit Value as Load Factors (3)
i)	One bathroom group consisting of water-closet, washbasin and bath tub or shower stall: a) Tank water-closet b) Flush-valve water-closed	6 8
ii)	Bath tub ¹⁾	3
iii)	Bidet	3
iv)	Combination sink-and-tray (drain board)	3
v)	Drinking fountain	½
vi)	Floor traps ²⁾	1
vii)	Kitchen sink, domestic	2
viii)	Wash basin, ordinary ³⁾	1
ix)	Washbasin, surgeon's	2
x)	Shower stall, domestic	2
xi)	Showers (group) per head	3
xii)	Urinal, wall lip	4
xiii)	Urinal, stall	4
xiv)	Water-closet, tank-operated	4
xv)	Water-closet, valve-operated	8

¹⁾ A shower head over a bath tub does not increase the fixture unit value.
²⁾ Size of floor trap shall be determined by the area of surface water to be drained.
³⁾ Washbasins with 32 mm and 40 mm trap have the same load value.

Table 5D.24 Fixture Unit Values for Fixtures Based on Fixture Drain on Trap Size

(Clause 5D.5.5.3.5.1)

SI No. (1)	Fixture Drain on Trap Size (2)	Fixture Unit Value (3)
i)	1¼ in and smaller	1
ii)	1½ in	2
iii)	2 in	3
iv)	2½ in	4
v)	3 in	5
vi)	4 in	6

Table 25 Maximum Number of Fixture Units that can be Connected to Branches and Stocks
(Clause 5.5.3.5.1)

Sl No.	Diameter of Pipe mm	Maximum Number of Fixture Units ¹⁾ that can be Connected			
		Any Horizontal Fixture Branch ²⁾	One Stack of 3 Storeys in Height or 3 Intervals	More Than 3 Storeys in Height	
(1)	(2)	(3)	(4)	Total for Stack (5)	Total at One Storey or Branch Interval (6)
i)	30	1	2	2	1
ii)	40	3	4	8	2
iii)	50	6	10	24	6
iv)	65	12	20	42	9
v)	75	20	30	60	16
vi)	100	160	240	500	90
vii)	125	360	540	1 100	200
viii)	150	620	960	1 900	350
ix)	200	1 400	2 200	3 600	600
x)	250	2 500	3 800	5 600	1 000
xi)	300	3 900	6 000	8 400	1 500
xii)	375	7 000	—	—	—

¹⁾ Depending upon the probability of simultaneous use of appliances considering the frequency of use and peak discharge rate.

²⁾ Does not include branches of the building sewer.

Table 26 Maximum Number of Fixture Units that can be Connected to Building Drains and Sewers
(Clause 5.5.3.5.1)

Sl No.	Diameter of Pipe mm	Maximum Number of Fixture Units that can be Connected to Any Portion ¹⁾ of the Building Drain or the Building Sewer for Gradient			
		1/200 (3)	1/100 (4)	1/50 (5)	1/25 (6)
(1)	(2)	(3)	(4)	(5)	(6)
i)	100	—	180	216	250
ii)	150	—	700	840	1 000
iii)	200	1 400	1 600	1 920	2 300
iv)	250	2 500	2 900	3 300	4 200
v)	300	3 900	4 600	5 600	6 700
vi)	375	7 000	8 300	10 000	12 000

¹⁾ Includes branches of the building sewer.

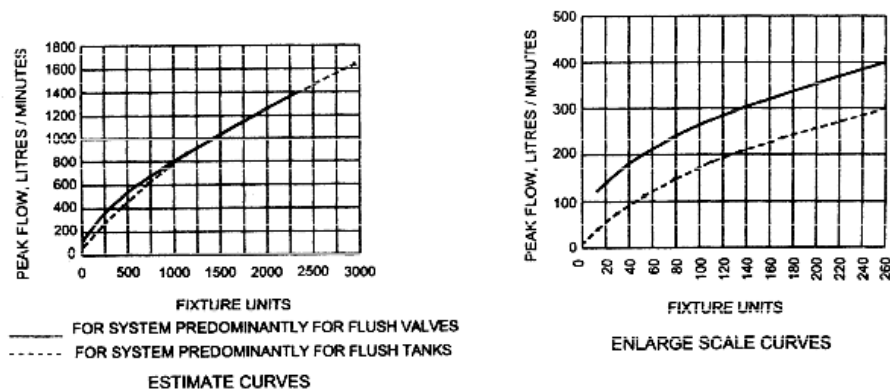

FIG. 5D.13 PEAK FLOW LOAD CURVES

5D.5.5.3.5.2.2

When flow occurs in drain piping, it should not entirely fill the cross-section of the pipe under flow condition. If the pipe were to flow full, pressure fluctuations would occur which could possibly destroy the seal of the traps within the building. Normally, the sewer shall be designed for discharging the peak flow as given in 5.5.3.5.1, flowing half-full with a minimum self-cleansing velocity of 2.5 ft/s. The approximate gradients which give this velocity for the sizes of pipes likely to be used in building drainage and the corresponding discharges when flowing half-full are given in Table 27.

5D.5.5.3.5.2.3

In cases where it is practically not possible to conform to the ruling gradients, a flatter gradient may be used, but the minimum velocity in such cases shall on no account be less than 2 ft/s and adequate flushing should be done.

NOTE — Where gradients are restricted, the practice of using a pipe of larger diameter than that required by the normal flow, in order to justify laying at a flatter gradient does not result in increasing the velocity of flow, further this reduces the depth of flow and thus for this reasons the above mentioned practice should be discouraged.

5D.5.5.3.5.2.4

On the other hand, it is undesirable to employ gradients giving a velocity of flow greater than 8 ft /s. Where it is unavoidable, cast iron pipes shall be used. The approximate gradients, which give a velocity of 8 ft/s for pipes of various sizes and the corresponding discharge when flowing half-full are given in Table 27.

5D.5.5.3.5.2.5

The discharge values corresponding to nominal diameter and gradient given in Table 27 are based on Manning's formula ($n = 0.015$).

NOTE — Subject to the minimum size of 4 inches, the sizes of pipes shall be decided in relation to the estimated quantity of flow and the available gradient.

Table 5D.27 Different Dia Pipes Giving Velocity and Corresponding Discharge at Minimum and Maximum Gradient
(Clauses 5.5.3.5.2.2, 5.5.3.5.2.4, 5.5.3.5.2.5)

SI No.	Diameter in	Minimum Gradient (Velocity:2.5 ft/s)	Discharge at the Minimum Gradient (ft ³ /s)	Maximum Gradient (Velocity:8 ft/s)	Discharge at the Maximum Gradient (ft ³ /s)
(1)	(2)	(3)	(4)	(5)	(6)
i)	4	1 in 57	0.11	1 in 5.6	0.35
ii)	6	1 in 100	0.25	1 in 9.7	0.78
iii)	8	1 in 145	0.43	1 in 14	1.41
iv)	9	1 in 175	0.55	1 in 17	1.75
v)	10	1 in 195	0.65	1 in 19	2.12
vi)	12	1 in 250	1.00	1 in 24.5	3.12

5D.5.5.3.6 Drain appurtenances

5D.5.5.3.6.1 Trap

All traps shall be protected against siphonage and back pressure ensuring access to atmospheric air for air circulation and preserving the trap seal in all conditions.

5D.5.5.3.6.1.1

A trap may be formed as an integral trap with the appliance during manufacture or may be a separate fitting called an attached trap which may be connected to the waste outlet of the appliance.

5D.5.5.3.6.1.2

Traps should always be of a self-cleansing pattern. A trap, which is not an integral part of an appliance, should be directly attached to its outlet and the pipe should be uniform throughout and have a smooth surface.

5D.5.5.3.6.1.3

The trap should have minimum size of outlet/exit, same as that of largest waste inlet pipe.

5D.5.5.3.6.1.4

Traps for use in domestic waste installations and all other traps should be conveniently accessible and provided with cleansing eyes or other means of cleaning.

5D.5.5.3.6.1.5

The minimum internal diameter for sanitary appliances shall be as follows:

Sanitary Appliance Internal Diameter of Waste Outlet (inches)	Minimum
<i>Soil appliances</i>	
a) Indian and European type water closets	4
b) Bed pan washers and slop sinks	4
c) Urinal with integral traps	3
d) Stall urinals (with not more than 5 inches of channel drainage)	2
e) Lipped urinal small/large 40	1½
<i>Waste appliances</i>	
f) Drinking fountain	1
g) Wash basin	1¼
h) Bidets	1¼
i) Domestic sinks and baths	1½
j) Shower bath trays	1½

PLUMBING SERVICES

k) Domestic bath tubs	2
l) Hotel and canteen sinks	2
m) Floor traps (outlet diameter)	2½

5D.5.5.3.6.2 Floor drains

All toilets/bathrooms in a building desirably should be provided with floor drains to facilitate cleaning.

5D.5.5.3.6.2.1

Floor drains shall connect into a trap so constructed that it can be readily cleaned and of a size to serve efficiently the purpose for which it is intended. The trap shall be either accessible from the floor drain or by a separate cleanout within the drain.

5D.5.5.3.6.2.2

Floor drain also receives, waste piping which does not connect to the sanitary system, known as indirect waste. This discharge from an indirect waste should be conveyed into a water supplied, trapped and vented floor drain.

5D.5.5.3.6.2.3

Floor drain should be provided in mechanical equipment rooms, where pumps, boilers, water chillers, heat exchangers and other air conditioning equipments are periodically drained for maintenance and repair. Boiler requires drain at safety relief valve discharge.

5D.5.5.3.6.2.4

Strategically floor drains are required to be located in buildings with wet fire protection sprinkler systems to drain water in case of activation of sprinkler heads.

5D.5.5.3.6.3 Cleanouts

The cleanout provides access to horizontal and vertical lines and stacks to facilitate inspection and means to remove obstructions common to all piping systems, such as solid objects, greasy wastes, hair and the like.

5D.5.5.3.6.3.1

Cleanouts in general should be gas and water-tight, provide quick and easy plug removal, allow ample space for rodding tools, have means of adjustments to finished floor level, be attractive and be designed to support whatever load is directed over them.

5D.5.5.3.6.3.2

Waste lines are normally laid beneath the floor slab at a sufficient distance to provide adequate back-fill over the joints. Cleanouts are then brought up to floor level grade by pipe extension pieces.

5D.5.5.3.6.3.3

The size of the cleanout within a building should be the same size as the piping up to 4 inches. For larger size piping 4 inches cleanouts are adequate for their intended purpose.

5D.5.5.3.6.3.4

Cleanouts are suggested to be provided at the following locations:

- a) Inside the building at a point of exit, Y junction branch or a trap.
- b) At every change of direction greater than 45°.
- c) At the base of all stacks.
- d) At the horizontal header, receiving vertical stacks and serving the purpose of offset header.

5D.5.5.4 Indirect Wastes**5D.5.5.4.1 General**

Waste, overflow and drain pipes from the following types of equipment shall not be connected into any drainage system directly to prevent backflow from the drainage system into the equipment/installation:

- a) **Plumbing and kitchen appliances.**
 - 1) Underground or overhead water tanks.
 - 2) Drinking water fountains.
 - 3) Dishwashing sinks and culinary sinks used for soaking and preparation of food.
 - 4) Cooling counters for food and beverages.
 - 5) Kitchen equipment for keeping food warm.
 - 6) Pressure drainage connections from equipment.
- b) **Air conditioning, heating and other mechanical equipments**
 - 1) Air handling equipment.
 - 2) Cooling tower and other equipments.
 - 3) Condensate lines from equipments
 - 4) Storage tanks.
 - 5) Condensate lines.
 - 6) Boiler blow down lines.
 - 7) Steam trap drain lines.
- c) **Laboratories and other areas**
 - 1) Water stills.
 - 2) Waste from laboratory in specified sinks.
 - 3) Sterilizers and similar equipments.
 - 4) Water purification equipments.

5D.5.5.4.2 Indirect waste receptors

All plumbing fixtures or other receptors receiving the discharge of indirect waste pipes shall be of such shape and capacity as to prevent splashing or flooding and shall be located where they are readily accessible for inspection and cleaning.

5D.5.5.4.3 Pressure drainage connections

Indirect waste connections shall be provided for drains, overflows or relief vents from the water supply system, and no piping or equipment carrying wastes or producing wastes or other discharges under pressure shall be directly connected to any part of the drainage system.

The above shall not apply to any approved sump pump or to any approved plumbing fixture discharging pressurized waste or device when the Authority has been satisfied that the drainage system has the capacity to carry the waste from the pressurized discharge.

5D.5.5.5 Special Wastes**5D.5.5.5.1 General**

Wastes having characteristics which may be detrimental to the pipes in which it is disposed as well as to the persons handling it. Such wastes used in a building need to be specially identified and a suitable and safe method of its disposal installed to ensure that the piping system is not corroded nor the health and safety of the occupants is affected in any way.

Whenever the occupant or the user of any wastes is unaware of the dangers of the consequences of disposing the waste, he shall be made aware of the dangers of his action along with providing suitable warning and instruction for correct disposal be provided to him.

Piping system for all special wastes should be separate and independent for each type of waste and should not be connected to the building drainage system. Other applicable provisions for installation of soil and waste pipe system shall be however be followed.

5D.5.5.5.2 Laboratory waste

A study of the possible chemical and corrosive and toxic properties of wastes handled and disposed off in a laboratory need to be ascertained in advance. The relevant statutory rules and regulation regarding the method of disposal of strong and objectionable wastes shall be followed.

All sinks, receptacles, traps, pipes, fittings and joints shall of materials resistant to the liquids disposed off in the system.

In laboratories for educational, research and medical institutions, handling mildly corrosive and toxic wastes, they may be neutralized in chambers using appropriate neutralizing agents. The chamber shall be provided with chambers at inlet and outlet for collecting samples of the incoming and outgoing waste for monitoring its characteristics.

5D.5.5.5.3 Infected wastes

Infected liquid wastes are generated in hospitals from patient excreta; operation theatres; laboratories testing samples of stools, urine, blood, flesh; etc which shall not be disposed off into the drainage system. Such waste shall be collected separately and pre-treated before disposal into the building drainage system.

Soiled and linen from infectious patients needs to be collected from the respective areas of the hospital in separate linen bins and pre-washed and sterilized in the laundry before final wash in the hospital laundry. Liquid wastes from the washing operations shall be neutralized to prevent any cross contamination before disposal in the building's drainage system.

5D.5.5.5.4 Research laboratory wastes

Research laboratories conducting research in all areas of science and technology, for example chemical industry, pharmacy, metallurgy, bio-sciences, agriculture, atomic energy, medicine, etc, shall follow the established procedures laid down by statutory bodies to handle, treat and dispose wastes which are highly toxic, corrosive, infectious, inflammable, explosive and having bacterial cultures, complex organic and inorganic chemicals. Such wastes shall not be disposed off in a building drainage system or the city sewerage system unless they are pre-treated and meet the disposal criteria in accordance with the relevant rules/regulations.

5D.5.5.6 Grease Traps

Oil and grease is found in wastes generated from kitchens in hotels, industrial canteens, restaurant, butcheries, some laboratories and manufacturing units having a high content of oil and greases in their

final waste.

Waste exceeding temperature of 60° C should not be allowed in the grease trap. When so encountered it may be allowed to cool in a holding chamber before entering the grease trap.

Oil and greases tend to solidify as they cool within the drainage system. The solidified matter clogs the drains and the other matter in the waste stick to it due to the adhesion properties of the grease. Oil and greases are lighter than water and tend to float on the top of the waste water.

Grease traps shall be installed in building having the above types of wastes. In principle the grease laden water is allowed to retain in a grease trap which enables any solids to be settled or separated for manual disposal. The retention time allows the incoming waste to cool and allow the grease to solidify. The clear waste is then allowed to discharge into the building's drainage system.

5D.5.5.7 Oil Interceptors

Oils and lubricants are found in wastes from vehicle service stations, workshops manufacturing units whose waste may contain high content of oils. Oils, for example, petroleum, kerosene and diesel used as fuel, cooking, lubricant oils and similar liquids are lighter than water and thus float on water in a pipe line or in a chamber when stored. Such oils have a low ignition point and are prone to catch fire if exposed to any flame or a spark and may cause explosion inside or outside the drainage system. The flames from such a fire spread rapidly if not confined or prevented at the possible source. Lighter oils and lubricants are removed from the system by passing them through an oil interceptor/petrol gully. They are chambers in various compartments which allow the solids to settle and allow the oils to float to the top. The oil is then decanted in separate containers for disposal in an approved manner. The oil free waste collected from the bottom of the chamber is disposed in the building drainage system.

5D.5.5.8 Radioactive Waste

Scientific research institutions, hospital and many types of manufacturing processes use radioactive material in form of radio isotopes and other radioactive sources for their activities. Manufacture, sale, use and disposal of radioactive material is regulated by the statutory rules and regulation. Proposal for usage and disposal of radioactive materials shall be done in consultation with and prior permission of the Authority by the users of the materials. No radioactive material shall be disposed off in any building drainage system without the authorization of the Authority.

5D.5.5.9 Special Situations of Waste Water Disposal

Buildings may generate uncontaminated waste water from various sources continuously, intermittently or in large volumes for a short time, for example, emptying any water tanks or pools, testing fire and water lines for flow conditions, etc. Connections from all such sources shall be made to the building drainage system indirectly through a trap. It should be ensured in advance that the building drain or a sump with a pump has the capacity to receive to rate of flow. In case the capacity is less the rate of discharge from the appliances should be regulated to meet the capacity of the disposal. Under no circumstances shall any waste water described above shall be disposed off in any storm water drains.

5D.5.5.10 Manholes

5D.5.5.10.1 General

A manhole or inspection chamber shall be capable of sustaining the loads which may be imposed on it, exclude sub-soil water and be water-tight. The size of the chamber should be sufficient to permit ready access to the drain or sewer for inspection, cleaning and rodding and should have a removable cover of adequate strength, constructed of suitable and durable material. Where the depth of the chamber so requires, access rungs, step irons, ladders or other means should be provided to ensure safe access to the level of the drain or sewer. If the chamber contains an open channel, benching should be provided having a smooth finish and formed so as to allow the foul matter to flow towards the pipe and also ensure a safe foothold.

No manhole or inspection chamber shall be permitted inside a building or in any passage therein. Further, ventilating covers shall not be used for domestic drains. At every change of alignment, gradient or diameter of a drain, there shall be a manhole or inspection chamber. Bends and junctions in the drains shall be grouped together in manholes as far as possible.

5D.5.5.10.2 Maximum Spacing of manhole

The maximum spacing of manholes for a given pipe size should be as follows:

Pipe Diameter	Maximum Spacing of Manhole
inches	feet
Up to 6	50
> 6 to 12	100
>12 to 18	150
>18 to 36	250

shall be covered over by a reinforced concrete slab of suitable dimensions with an opening for manhole cover and frame.

5D.5.5.10.4 Construction

5D.5.5.10.4.1 Excavation

The manhole shall be excavated true to dimensions and levels as shown on the plan. The excavation of deep manholes shall be accompanied with safety measures like timbering, staging, etc. In areas where necessary, appropriate measures for dewatering should be made.

5D.5.5.10.4.2 Bed Concrete

The manhole shall be built on a bed of concrete 1:4:8 (1 cement: 4 coarse sand: 8 graded stone aggregate 1½ in nominal size). The thickness of bed concrete shall be at least 6 in for manholes up to 3 feet in depth, at least 8 inches for manholes from 3 feet upto 8 feet in depth and at least 1 ft for manholes of greater depth, unless the structural design demands higher thickness.

This thickness may be verified considering the weight of wall, cover, the wheel loads, impact of traffic which are transmitted through cover and the shaft walls and for water pressure, if any. In case of weak soil, special foundation as suitable shall be provided.

5D.5.5.10.4.3 Brickwork

The thickness of walls shall be designed depending upon its shape and taking onto account all loads coming over it, including earth pressure and water pressure.

Generally the brickwork shall be with first class bricks in cement mortar 1:5 (1 cement: 5 coarse sand). All brickwork in manhole chambers and shafts shall be carefully built in English Bond, the jointing faces of each brick being well "battered" with cement mortar before laying, so as to ensure a full joint. The construction of walls in brickwork shall be done in accordance with good practice [9-1(26)].

For various depths the recommended thickness of wall may be as follows:

Depth of the Chamber	Thickness of Wall
a) Up to 7 feet 6 inches	8 inches (one brick length)
b) From 7 feet 6 inches up to 10 feet	1 feet (one and half brick length)
c) From 10 feet up to 16 feet 6 inches	1 feet 4 inches (two brick length)
d) From 16 feet 6 inches up to 29 feet 6 inches	1 feet 8 inches (two and half brick length)
e) Above 29 feet 6 inches	2 feet (three brick length)

The actual thickness in any case shall be calculated on the basis of engineering design. Typical sections of the manholes are illustrated in Fig. 14, 15 and 16.

NOTES

- 1 Rich mix of cement mortar, not weaker than 1:3, should be used in brick masonry, where sub-soil water conditions are encountered.

- 2 For arched type of manholes, the brick masonry in arches and arching over pipes shall be in cement mortar 1:3.

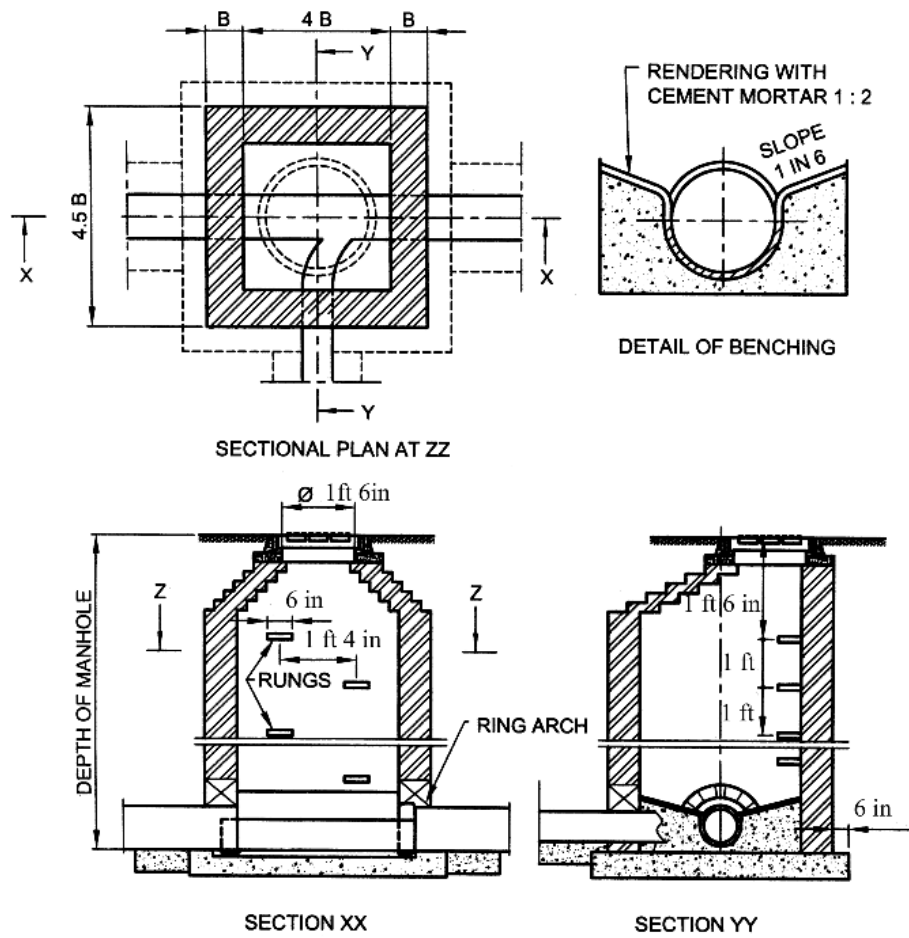

Fig. 5d.14 Detail Of Manhole (Depth Less Than 3 Feet)

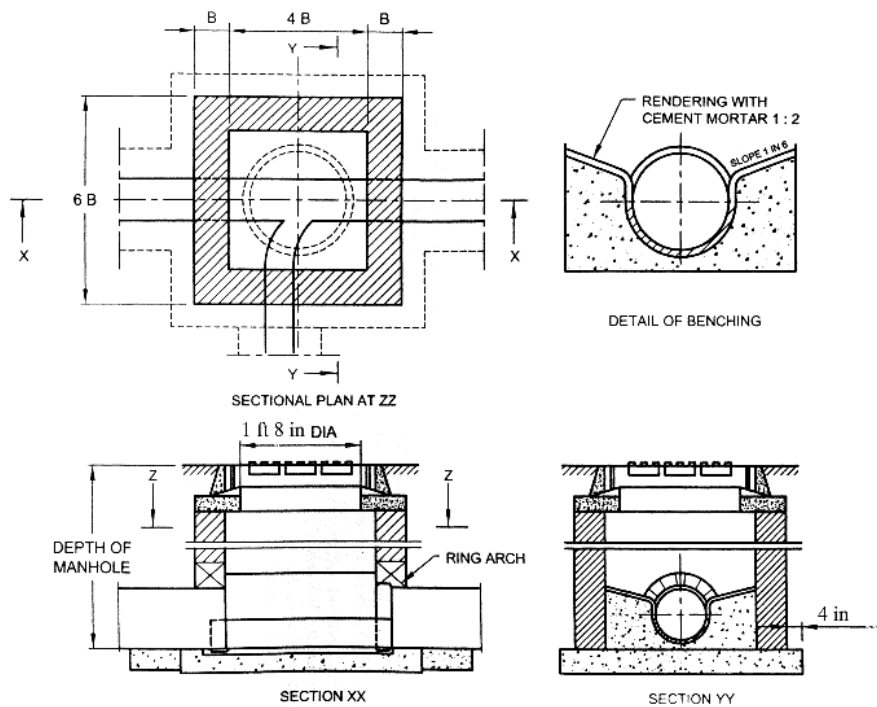

Fig. 5d.15 Detail Of Manhole (Depth 3 Feet And Up To 8 Feet)

5D.5.5.10.4.4 Plastering

The wall shall be plastered (½ inches, Min) both inside and outside within cement mortar 1:3 and finished smooth with a coat of neat cement. Where sub-soil water conditions exist, a richer mix may be used and it shall further waterproofed with addition of approved waterproofing compound in a quantity as per manufacturer specifications.

All manholes shall be so constructed as to be watertight under test.

All angles shall be rounded to 3 inches radius and all rendered internal surface shall have hard impervious finish obtained using a steel trowel.

5D.5.5.10.4.5 Channels and benching

These shall be semi-circular in the bottom half and of diameter equal to that of the sewer. Above the horizontal diameter, the sides shall be extended vertically 2 inches above the crown of sewer pipe and the top edge shall be suitably rounded off. The branch channels shall also be similarly constructed with respect to the benching, but at their junction with the main channel an appropriate fall, if required suitably rounded off in the direction of flow in the main channel shall be given.

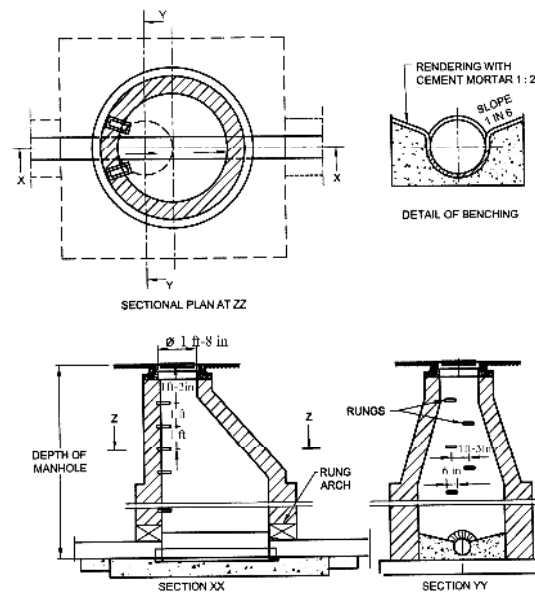

Fig. 5d.16 Detail Of Manhole (Depth 8 Ft And Above)

The channel/drain and benching at the bottom of the chamber shall be done in cement concrete 1:2:4 and subsequently plastered with cement mortar of 1:2 proportion or weaker cement mortar with a suitable waterproofing compound and finished smooth, to the grade (where required). The benching at the sides shall be carried up in such a manner as to provide no lodgment for any splashing in case of accidental flooding of the chamber.

Channels shall be rendered smooth and benchings shall have slopes towards the channel.

5D.5.5.10.4.6 Rungs

Rungs shall be provided in all manholes over 2 feet 6 inches in depth and shall be of preferably of cast iron and of suitable dimensions, conforming to accepted standards [9-1(27)]. These rungs may be set staggered in two vertical rungs which may be 1 foot apart horizontally as well as vertically and shall project a minimum of 4 inches beyond the finished surface if the manhole wall. The top rung shall be 1 foot 6 inches below the manhole cover and the lowest not more than 1 foot above the benching.

5D.5.5.10.4.7 Manhole covers and frames

The size of manhole covers shall be such that there shall be a clear opening of at least 1 foot 8 inches in diameter for manholes exceeding 3 feet in depth. The manhole covers and frames are used they shall conform to accepted standards [9-1(28)].

The frame of manhole shall be firmly embedded to concrete alignment and level in plain concrete on the top of masonry.

5D.5.5.10.5 Drop manhole

Where it is uneconomic or impracticable to arrange the connection within 2 feet height above the invert of the manholes, the connection shall be made by constructing a vertical shaft outside the manhole chamber, as shown in Fig. 17. If the difference in level between

the incoming drain and the sewer does not exceed 2 feet, and there is sufficient room in the manhole, the connecting pipe may be directly brought through the manhole wall and the fall accommodated by constructing a ramp in the benching of the manhole.

For detailed information regarding manholes in sewerage system, reference may be made to good practice [9-1(29)].

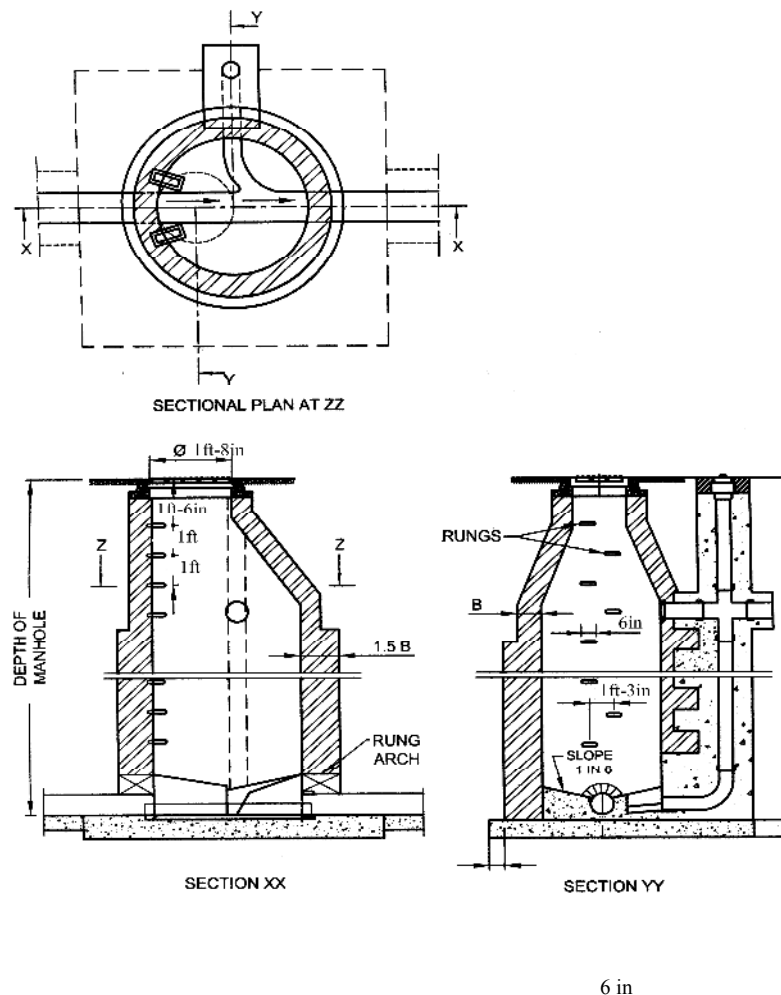

NOTE – Wall thickness have been indicated in brick length to provide for use of modular bricks or traditional bricks. In the Fig. B = one brick length, 1.5B = one and a half brick length etc.

5D.5.5.11 Storm Water Drainage

5D.5.5.11.1 General

The object of storm water drainage is to collect and carry, the rain-water collected within the premises of the building, for suitable disposal.

5D.5.5.11.2 Design factors

Estimate of the quantity that reaches the storm water drain depends on the following factors:

- a) Type of soil and its absorption capacity determined by its soil group.
- b) Ground slope and the time in which the area is drained.

- c) Intensity of the rainfall for a design period.
- d) Duration of the rain/storm.

5D.5.5.11.2.1 Imperviousness

The soil conditions and the ground slope determine the impermeability factor. Impermeability factor is the proportion of the total rainfall received on the surface which will be discharging into the a storm water drain after allowing for initial abstraction (in local pond and lakes), ground absorption by evaporation, vegetation and other losses. The net flow reaching the storm water drain is called runoff.

The percentage of imperviousness of the drainage area may be obtained from available data for a particular area. In the absence of such data, the following values may serve as a guide:

Type of area	Imperviousness factor(<i>percent</i>)
Commercial and industrial areas	70-90
Residential areas (high density)	60-75
Residential areas (low density)	35-60
Parks and underdeveloped areas	10-20

5D.5.5.11.2.2 Terrain modelling

Areas planned for urbanization from agricultural land, forest or low grade land for example, low lying areas prone to flooding, marshy or abandoned quarries, etc need detailed and careful consideration with respect to its drainage. A detailed contour survey shall be carried out not only with respect to the site but also the surrounding areas to verify the quantity/area contributing runoff, presence of any low lying and natural water body acting as holding pond or any natural drain passing through the area and beyond whose filling up or diversion may cause water logging problem on the site or to the surrounding areas.

The planning of the area should ensure that:

- a) All areas become self draining by gravity with respect to the high flood level of the area or the drainage channels passing whichever is higher.
- b) As far as possible, natural drainage pattern with respect to the whole area be maintained except when low lying areas need to be filled up for grading purposes.
- c) The drainage in the area shall be planned in accordance with the natural slopes.
- d) Levels of the main highway or road connecting to the property shall be determined to ensure proper drainage and protection of the site.
- e) The formation levels of the entire area shall be prepared to determine proposed formation levels by preparing a terrain model which will show the proposed the site contours, ground and road levels and connections to all services including storm water disposal system.

5D.5.5.11.2.3 Design frequency

Storm water drainage system for an urbanized area is planned on the basis of the design frequency of the storm which shall be determined by the designer. Frequency is the period in which the selected design intensity recurs in a given period of time in years.

5D.5.5.11.2.4 Time of concentration

Time of concentration is the time required for the rainwater to flow to reach the farthest point of the drainage system or the outfall under consideration. Time of concentration is equal to the inlet time plus the time required for the flow to reach the main or branch drain. The inlet time is the time dependent on the distance of the farthest point in the drainage area to the inlet of the manhole and the surface slopes, etc and will vary between 5 min to 30 min.

In highly developed sections for example with impervious surfaces it may be as low as 3 min or lower (with good slopes) as in building terraces and paved areas. Correspondingly the design intensity for the drainage for such areas will be much higher. Rainwater pipes have to be designed for an intensity for a very low time of concentration.

5D.5.5.11.2.5 Natural infiltration

In planning any area with buildings, layout with paved and non-permeable surfaces, care should be taken to allow maximum discharge of the rain-water to flow directly or indirectly to permeate into the ground for enabling the ground water to be recharged. Some of the techniques which allow infiltration that may be considered are:

- a) Use of brick paved open jointed storm water drains.
- b) Providing bore holes in the storm water drains.
- c) Using paving tiles with open joints which enable water to percolates as it flows on it.

5D.5.5.11.3 Combined system

A combined system of drainage is one which carries the sewerage as well as the runoff from the storm water drainage. Relevant applicable statutory rules/ regulations may not allow such system in new areas and the sewerage and the storm water drainage have to be separate and independent of each other. Such systems are however existing in many old cities and the storm water may have to be discharged into the combined drainage system.

Where levels do not permit for connection to a public storm water drain, storm water from courtyards of buildings may be connected to the public sewer, provided it is designed to or has the capacity to convey combined discharge. In such cases, the surface water shall be admitted to the soil sewer through trapped gullies in order to prevent the escape of foul air.

5D.5.5.11.4 Discharging into a watercourse

It may often be convenient to discharge surface water to a nearby stream or a watercourse. The invert level of the outfall shall be about the same as the normal water level in the watercourse or ideally should be above the highest flood level of the watercourse. The out-fall shall be protected against floating debris by a screen.

5D.5.5.11.5 Discharge to a public storm water drain

Where it is necessary to connect the discharge rainwater into a public storm water drain, such drains shall be designed for the intensity of rain based on local conditions, but in no case shall they be designed for intensity of rainfall of less than 2 inches / hour. Rainwater from each building plot shall be connected to the storm water drainage through a separate pipe or an open public drain directly. No trap shall be installed before the connection.

5D.5.5.11.6 Rain-water pipes for roof drainage**5D.5.5.11.6.1**

The roofs of a building shall be so constructed or framed as to permit effectual drainage of the rain-water there from by means of a sufficient number of rain-water pipes of adequate size so arranged, jointed and fixed as to ensure that the rainwater is carried away from the building without causing dampness in any part of the walls or foundations of the building or those of an adjacent building.

5D.5.5.11.6.2

The rain-water pipes shall be fixed to the outside of the external walls of the building or in recesses or chases cut or formed in such external wall or in such other manner as may be approved by the Authority.

5D.5.5.11.6.3

Rain-water pipes conveying rain- water shall discharge directly or by means of a channel into or over an inlet to a surface drain or shall discharge freely in a compound, drained to surface drain but in no case shall it discharge directly into any closed drain.

5D.5.5.11.6.4

Whenever it is not possible to discharge a rain-water pipe into or over an inlet to a surface drain or in a compound or in a street drain within 100 ft from the boundary of the premises, such rain-water pipe shall discharge into a gully trap which shall be connected with the street drain for storm water and such a gully- trap shall have a screen and a silt catcher incorporated in its design.

5D.5.5.11.6.5

If such streets drain is not available within 100ft of the boundary of the premises, a rain-water pipe may discharge directly into the kerb drain and shall be taken through a pipe outlet across the foot path, if any, without obstructing the path.

5D.5.5.11.6.6

A rain water pipe shall not discharge into or connect with any soil pipe or its ventilating pipe or any waste pipe or its ventilating pipe nor shall it discharge into a sewer unless specifically permitted to do so by the Authority, in which case such discharge into a sewer shall be intercepted by means of a gully trap.

5D.5.5.11.6.7

Rain-water pipes shall be constructed of cast iron, PVC, asbestos cement, galvanized sheet or other equally suitable material and shall be securely fixed.

5D.5.5.11.6.8

The factors that decide the quantity of rain water entering are:

- a) Intensity of rainfall, and
- b) Time of concentration selected for rain-water pipe.

A bell mouth inlet at the roof surface is found to give better drainage effect, provided proper slopes are given to the roof surface. The spacing of rain-water pipes depends on the locations available for the down takes and the area which each pipe serves. The spacing will also be determined by the amount of slopes that can be given to the roof. The recommended slopes for the flat roofs with smooth finish would be 1:150 to 1:133, with rough stone/tiles 1:100 and for gravel set in cement or losely packed concrete finish 1:75 to 1:66. The effective strainer area should preferably be 1.5 to 2 times the area of pipe to which it connects to considerably enhance the capacity of rain water pipes.

The rain water pipes of cast iron (coefficient of roughness 0.013) shall normally be sized on the basis of roof areas according to Table 28. The vertical down take rain-water pipes, having a bell mouth inlet on the roof surface with effective cross-sectional area of grating 1.5 to 2 times the rain-water pipe area, may be designed by considering the outlet pipe as weir.

For full circumference of pipe acting as weir, the roof area (RA) for drainage may be worked out by using $RA = 0.084 \times d^{5/2} / I$

Where d = Pipe diameter; inches
 I = Intensity of rainfall (inches / hour)

Table 5D.28 Sizing of Rain-Water Pipes for Roof Drainage
 (Clause 5.5.11.6.8)

Dia of Pipe (in)	Average Rate of Rainfall (inches / hour)					
	Roof Area (ft ²)					
	2	3	4	5	6	7
2	144.24	95.80	71.04	57.05	47.36	35.52
2½	259.41	172.23	129.17	103.33	86.11	64.58
3	439.17	290.63	219.59	175.45	146.39	109.79
4	919.25	613.55	459.62	368.13	306.77	229.27
5	1719.12	1148.84	866.50	692.13	575.87	430.56
6	2686.69	1795.65	1348.41	107.64	899.87	674.90

NOTE – For rain-water pipes of other materials, the roof areas shall be multiplied by (0.013/coefficient of roughness of surface of that material).

5D.5.5.11.6.9

The storm water may be led off in a suitable open drain to a watercourse. The open drain, if not a *pucca* masonry throughout, shall be so at least where there is either a change in direction or gradient.

5D.5.5.12 Rain-water Harvesting

5D.5.5.12.1 General

To supplement the ever growing shortage of protected, pure and safe water supply for human consumption rainwater is an ideal source which can be conserved and used in a useful manner by the people. The amount of rainfall available varies from region to region. Each area has to develop its own method and system to conserve, store and use it to suit its requirements and local conditions. There are several methods by which rain-water can be stored, used and conserved. Each system depends on the amount of precipitation, the period in which the rainfall occurs in a year and the physical infrastructure for example, space available to store the water, etc.

There are several techniques available for catching and storing the rain-water. Most of the techniques are applicable for large open areas, farms, sloping grounds etc, with a low population base. Two major systems that are ideal for urban and semi-urban developed areas are:

- a) Artificial ground water recharge, and
- b) Roof top rain-water harvesting.

5D.5.5.12.2 Artificial ground water recharge

With increase in the impermeable surfaces in modern built up areas, a large quantity of water normally percolating into the ground runs off to the natural drains and into the rivers causing increased runoff and flooding of downstream areas as it also deprives the original catchment area of the natural percolation that would have recharged the area in the normal course if the ground was in its natural condition for example a farm, open ground, forest, etc. It is therefore essential to catch the runoff and use it for augmentation of ground water reservoir by modifying the natural movement of surface water by recharging it by artificial means for example, construction of recharge structures (*see* Fig. 18). The main objectives achieved may be:

- a) Enhancement of sustainable yield in areas where there is over development and depletion of the aquifers.
- b) Conservation and storage of excess surface water in the aquifers.
- c) Improve the quality of the existing ground water through dilution.
- d) Remove bacteriological and suspended impurities during the surface water transition within the sub-soil.
- e) Maintain the natural balance of the ground water and its usage as the rain-water is a renewable supply source. A well managed and controlled tapping of the aquifers will provide constant, dependable and safe water supply.

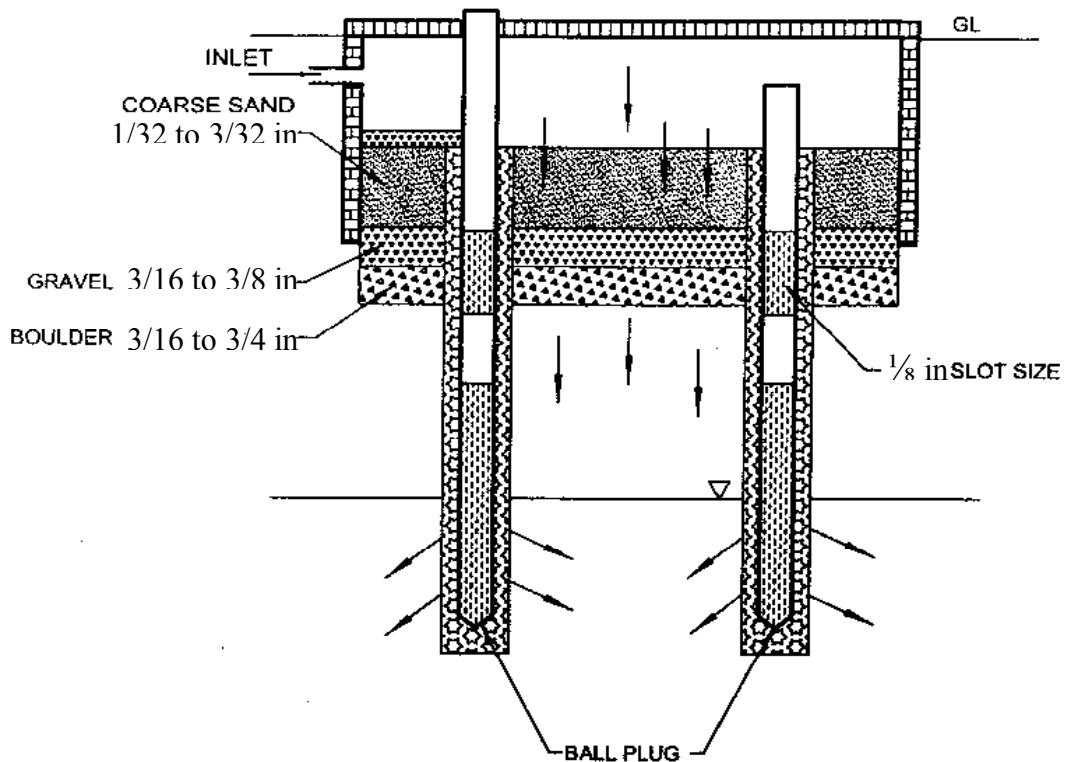

Fig. 5d.18 Artificial Ground Water Recharge Structure

In planning and designing the ground water recharge structures following should be taken into consideration:

- a) Annual rainfall (for estimating approx rainwater recharge per year).
- b) Peak intensity and duration of each storm.
- c) Type of soil and sub-soil conditions and their permeability factor.
- d) Ground slopes and runoff which cannot be caught.
- e) Location of recharge structures and its overflow outfall.
- f) Rainwater measuring devices for finding the flow of water in the system.

For artificial recharge to ground water, Guidelines for Artificial Recharge to Ground Water (*under preparation*) may be referred.

5D.5.5.12.3 Roof top rain-water harvesting

5D.5.5.12.3.1 Harvesting in regular rainfall areas

In areas having rainfall over a large period in a year for example, in hilly areas and coastal regions, constant and regular rainfall can be usefully harvested and stored in suitable water tanks. Water is collected through roof gutters and down take pipes. Provision should be made to divert the first rainfall after a dry spell so that any dust, soot, leaves etc, are drained away before the water is collected into the water tank. The capacity of the water tank should be enough for storing water required for consumption between two dry spells. The water tank shall be located in a well protected area and should not be exposed to any hazards of water contamination from any other sources. The water shall be chlorinated using chlorine tablets or solution to maintain a residual

chlorine of approximately 1 ppm. The tank must have an overflow leading to a natural water courses or to any additional tanks (see Table 5D.29).

Table 5D.29 Rainwater Available from Roof Top Harvesting
(Clause 5.5.12.13.1)

Rain Fall (inch)	3	6	9	12	15	18	21	24	27	30	33	36	39	42	45	48	51	54	57	60
Roof Top Area (ft²)	Harvested Water from Roof Tops (x 10³ ft³) (80 percent of gross precipitation)																			
100	0.02	0.04	0.06	0.08	0.1	0.12	0.14	0.16	0.18	0.2	0.22	0.24	0.26	0.28	0.3	0.32	0.34	0.36	0.38	0.4
200	0.04	0.08	0.12	0.16	0.2	0.24	0.28	0.32	0.36	0.4	0.44	0.48	0.52	0.56	0.6	0.64	0.68	0.72	0.76	0.8
300	0.06	0.12	0.18	0.24	0.3	0.36	0.42	0.48	0.54	0.6	0.66	0.72	0.78	0.84	0.9	0.96	1.02	1.08	1.14	1.2
400	0.08	0.16	0.24	0.32	0.4	0.48	0.56	0.64	0.72	0.8	0.88	0.96	1.04	1.12	1.2	1.28	1.36	1.44	1.52	1.6
500	0.1	0.2	0.3	0.4	0.5	0.6	0.7	0.8	0.9	1	1.1	1.2	1.3	1.4	1.5	1.6	1.7	1.8	1.9	2
600	0.12	0.24	0.36	0.48	0.6	0.72	0.84	0.96	1.08	1.2	1.32	1.44	1.56	1.68	1.8	1.92	2.04	2.16	2.28	2.4
700	0.14	0.28	0.42	0.56	0.7	0.84	0.98	1.12	1.26	1.4	1.54	1.68	1.82	1.96	2.1	2.24	2.38	2.52	2.66	2.8
800	0.16	0.32	0.48	0.64	0.8	0.96	1.12	1.28	1.44	1.6	1.76	1.92	2.08	2.24	2.4	2.56	2.72	2.88	3.04	3.2
900	0.18	0.36	0.54	0.72	0.9	1.08	1.26	1.44	1.62	1.8	1.98	2.16	2.34	2.52	2.7	2.88	3.06	3.24	3.42	3.6
1000	0.2	0.4	0.6	0.8	1	1.2	1.4	1.6	1.8	2	2.2	2.4	2.6	2.8	3	3.2	3.4	3.6	3.8	4
1100	0.22	0.44	0.66	0.88	1.1	1.32	1.54	1.76	1.98	2.2	2.42	2.64	2.86	3.08	3.3	3.52	3.74	3.96	4.18	4.4
1200	0.24	0.48	0.72	0.96	1.2	1.44	1.68	1.92	2.16	2.4	2.64	2.88	3.12	3.36	3.6	3.84	4.08	4.32	4.56	4.8
1300	0.26	0.52	0.78	1.04	1.3	1.56	1.82	2.08	2.34	2.6	2.86	3.12	3.38	3.64	3.9	4.16	4.42	4.68	4.94	5.2
1400	0.28	0.56	0.84	1.12	1.4	1.68	1.96	2.24	2.52	2.8	3.08	3.36	3.64	3.92	4.2	4.48	4.76	5.04	5.32	5.6
1500	0.3	0.6	0.9	1.2	1.5	1.8	2.1	2.4	2.7	3	3.3	3.6	3.9	4.2	4.5	4.8	5.1	5.4	5.7	6
2000	0.4	0.8	1.2	1.6	2	2.4	2.8	3.2	3.6	4	4.4	4.8	5.2	5.6	6	6.4	6.8	7.2	7.6	8
2500	0.5	1	1.5	2.0	2.5	3	3.5	4	4.5	5	5.5	6	6.5	7	7.5	8	8.5	9	9.5	10
3000	0.6	1.2	1.8	2.4	3	3.6	4.2	4.8	5.4	6	6.6	7.2	7.8	8.4	9	9.6	10.2	10.8	11.4	12
4000	0.8	1.6	2.4	3.2	4	4.8	5.6	6.4	7.2	8	8.8	9.6	10.4	11.2	12	12.8	13.6	14.4	15.2	16
5000	1	2	3	4	5	6	7	8	9	10	11	12	13	14	15	16	17	18	19	20
10000	2	4	6	8	10	12	14	16	18	20	22	24	26	28	30	32	34	36	38	40
20000	4	8	12	16	20	24	28	32	36	40	44	48	52	56	60	64	68	72	76	80
30000	6	12	18	24	30	36	42	48	54	60	66	72	78	84	90	96	102	108	114	120

5D.5.5.12.3.2 Harvesting in urban areas

In urban areas with the rainfall limited during the monsoon period (usually from 15-90 days) roof top rain-water cannot be stored and used as mentioned above and is best used for recharging the ground water. For individual properties and plots the roof top rainwater should be diverted to existing open or abandoned tube wells. In a well building complex the system should be laid out so that the runoff is discharged in bore-wells as per designs specified by the Authority.

For roof top rain water harvesting in hilly areas reference may be made to good practice [9-1(30)].

5D.5.5.12.4 Care to taken in rain-water harvesting

Water conservation technique discussed above shall be constructed with due care taking following precautions:

- a) No sewage or waste water should be admitted into the system.

- b) No waste water from areas likely to have oil, grease or other pollutants should be connected to the system.
- c) Each structure/well shall have an inlet chamber with a silt trap to prevent any silt from finding its way into the sub-soil water.
- d) The wells should be terminated at least 16 feet 6 inches above the natural static sub-soil water at its highest level so that the incoming flow passes through the natural ground condition and prevents contamination hazards.
- e) No recharge structure or a well shall be used for drawing water for any purpose.

5D.5.5.13 Sub-soil Water Drainage

5D.5.5.13.1 General

Sub-soil water is that portion of the rainfall which is absorbed into the ground.

The drainage of sub-soil water may be necessary for the following reasons:

- a) to avoid surface flooding;
- b) to alleviate or to avoid causing dampness in the building, especially in the cellars;
- c) to reduce the humidity in the immediate vicinity of the building; and
- d) to increase the workability of the soil.

5D.5.5.13.2 Depth of water table

The standing level of the sub-soil water will vary with the season, the amount of rainfall and the proximity and level of drainage channels. Information regarding this level may be obtained by means of boreholes or trial pits, preferably the latter. It is desirable though not always practicable to ascertain the level of the standing water over a considerable period so as to enable the seasonal variations to be recorded and in particular the high water level. The direction of flow of the sub-soil water may usually be judged by the general inclination of the land surface and the main lines of the subsoil drains shall follow the natural falls, wherever possible.

5D.5.5.13.3 Precautions

Sub-soil drains shall be so sited as not to endanger the stability of the buildings or earthwork. In some portions of the drain, it may be necessary to use non-porous jointed pipes.

5D.5.5.13.3.1

No field pipe shall be laid in such a manner or in such a position as to communicate directly with any drain constructed or adopted to be used for conveying sewage, except where absolutely unavoidable and in such case a suitable efficient trap shall be provided between sub-soil drain and such sewer.

5D.5.5.13.4 Systems of sub-soil drainage

Clay or concrete porous field drain pipes may be used and shall be laid in one of the following ways (*see also* Fig, 19):

- a) *Natural* — The pipes are laid to follow the natural depressions or valleys of the site; branches discharge into the main as tributaries do into a river.

- b) **Herringbone** — The system consists of a number of drains into which discharges from both sides smaller subsidiary branch drains parallel to each other, but at an angle to the mains forming a series of herringbone pattern. Normally these branch drains should not exceed 30 m in length.
- c) **Grid** — A main or mains drain is laid to the boundaries of the site into which subsidiary branches discharge from one side only.
- d) **Fan-Shaper**—The drains are laid converging to a single outlet at one point on the boundary of a site, without the use of main or collecting drains.
- e) **Moat or cut-off system** — This system consists of drains laid on one or more sides of a building to intercept the flow of subsoil water and carry it away, thereby protecting the foundations of a building.

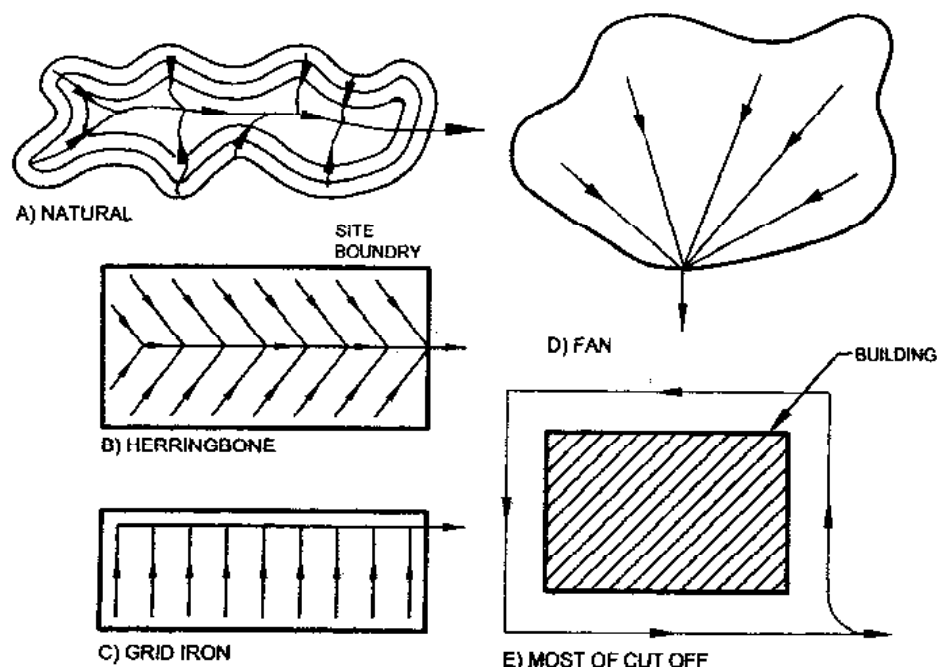

Fig. 19 Details Of Drainage System

The choice of one or more of these systems will naturally depend on the local conditions of the site. For building sites, the mains shall be not less than 3 inches in diameter and the branches not less than $2\frac{1}{2}$ inches in diameter and the branches not less than $2\frac{1}{2}$ inches in diameter but normal practice tends towards the use of 4 inches and 3 inches respectively. The pipes shall generally be laid at 2 feet to 3 feet depth, or to such a depth to which it is desirable to lower the water-table and the gradients are determined rather by the fall of the land than by considerations of self-cleansing velocity. The connection of the subsidiary drain to the main drain is best made by means of a clay ware or concrete junction pipe. The outlet of a sub-soil system may discharge into a soak away or through a catch pit into the nearest ditch or watercourse. Where these are not available, the sub-soil drains may be connected, with the approval of the Authority, through an intercepting trap to the surface water drainage system,

NOTE — Care shall be taken that there is no backflow from sub-surface drains during heavy rains.

5D.5.5.14 Waste Disposal Systems in High Altitudes and or Sub-zero Temperature Regions

5D.5.5.14.1

In general, all the cases to be exercised regarding water supply systems shall also be applicable in the case of waste disposal systems shall also be applicable in the case of waste disposal systems. The biological and chemical reduction of organic material proceeds slowly under low temperature conditions, consequently affecting the waste disposal systems. The waste disposal methods given in 5.5.14.2, 5.5.14.3 and 5.5.14.4 shall be used only where it is not practical to install water carriage system.

5D.5.5.14.2 Box and can system

Where box and can systems are employed, adequate arrangements shall be made for the cleaning and disinfection of the can after it is emptied of its contents. The excrement from the can shall be disposed of by burial in isolated spots far from habitation or by incineration, where feasible. The can shall be fitted with a tight fitting lid for use when it is carried for emptying.

5D.5.5.14.3 Trench or pit latrines

Trench or pit latrines shall be used only where soil and sub-soil conditions favour their use. Whenever they are used, they shall not be closer than 60 ft from any source of drinking water, such as well, to eliminate the possibility of bacterial pollution of water.

5D.5.5.14.4 Chemical toilets

For the successful functioning of chemical toilets, they shall preferably be installed in heated rooms or enclosures.

NOTE — Chemical toilet essentially consists of small cylindrical tanks with a water-closet seat for the use of 8 to 10 persons. A ventilation pipe is fitted to the seat. A strong solution of caustic soda is used as a disinfectant. It kills bacteria, liquefies the solids and thus checks the decomposition of organic matter. The tank is provided with a drain plug for which liquid runs to a soak pit at the time of disposal.

5D.5.5.14.5 Water-borne sanitation systems

Water-borne sanitation systems shall be used, where practicable. Sanitation systems for the collection of sewage should be constructed in such a manner that maximum heat is retained by insulation, if necessary.

5D.5.5.14.5.1 Sewerage laying

Under normal circumstances, sewers shall be laid below the frost line. Manholes shall be made of airtight construction so as to prevent the cold air from gaining access inside and freezing the contents. The trenches for sewers shall be loosely filled with earth after laying sewers, since loose soil is a better insulator than compacted soil. Consequently, sewers laid under traffic ways and other places where soil compaction may be expected are required to be given adequate insulation. Where feasible, sewers shall be so located that the trench line is not in shadow, when the sun is shining.

Concrete, cast iron and stoneware pipes conduct heat relatively rapidly and as such should be adequately insulated.

5D.5.5.14.5.2 Septic tanks

Septic tanks can function only when it can be ensured that the contents inside these do not freeze at low temperature. For this purpose, the septic tanks shall be located well below the frost line. The location of manhole openings shall be marked by staves. Fencing around the septic tanks shall be provided for discouraging traffic over them. As the rate of biological activity is reduced by 50 percent for every 10°C fall in temperature, the capacity of septic tanks shall be increased by 100 percent for operation at 10°C over that for operation at 20°C.

5D.5.5.14.5.3 Seepage pits

Seepage pits can function only when the soil and subsoil conditions are favourable. Frozen soil extending to a great depth would preclude the use of such disposal devices in view of the lower water absorption capacity. The discharge of effluent should be made below the frost line.

5D.5.5.14.5.4 Sewage treatment plants

Suitable design modifications for sedimentation, chemical and biological processes shall be applied to sewage treatment plants for satisfactory functioning.

NOTE — Lavatories and bathrooms shall be kept heated to avoid freezing of water inside traps and flushing cisterns.

5D.5.6 Construction Relating to Conveyance of Sanitary Wastes

5D.5.6.1 Excavation

5D.5.6.1.1 General

The safety precautions as given in Part 7 'Constructional Practices and Safety' shall be ensured.

5D.5.6.1.2

Turf, topsoil or other surface material shall be set aside, turf being carefully rolled and stacked for use in reinstatement. All suitable broken surface material and hard-core shall be set on one side for use in subsequent reinstatement.

5D.5.6.1.3

Excavated material shall be stacked sufficiently away from the edge of the trench and the size of the spoil bank shall not be allowed to become such as to endanger the stability of the excavation. Spoil may be carried away and used for filling the trench behind the work.

5D.5.6.1.4

Excavation shall proceed to within about 3 inches of the finished formation level. This final 3 inches is to be trimmed and removed as a separate operation immediately prior to the laying of the pipes or their foundations.

5D.5.6.1.5

Unless specified otherwise by the Authority, the width at bottom of trenches for pipes of different diameters laid at different depths shall be as given below:

- a) For all diameters, up to an average depth of 4 ft, width of trench in ft = diameter of pipe + 1 ft;
- b) For all diameters for depths above 4 ft; width of trench in ft = diameter of pipe + 1½ ft; and
- c) Notwithstanding (a) and (b), the total width of trench at the top should not be less than 2 ft 6 in for depths exceeding 3 ft.

5D.5.6.1.6

Excavation in roads shall be so arranged, in agreement with the proper authority, as to cause the minimum obstruction to traffic. The methods to be adopted shall depend on local circumstances.

5D.5.6.1.7

All pipes, ducts, cables, mains or other services exposed in the trench shall be effectively supported by timber and/or chain or rope-slings.

5D.5.6.1.8

All drainage sumps shall be sunk clear of the work outside the trench or at the sides of manholes. After the completion of the work, any pipes or drains leading to such sumps or temporary sub-soil drains under permanent work shall be filled in properly with sand and consolidated.

5D.5.6.2 Laying of Pipes

Laying of pipes shall be done in accordance with good practice [9-1(31)].

5D.5.6.3 Jointing

All soil pipes, waste pipes, ventilating pipes and other such pipes above ground shall be gas-tight. All sewers and drains laid below the ground shall be water-tight. Jointing shall be done in accordance with good practice [9-1(31)].

5D.5.6.4 Support or protection for pipes

5D.5.6.4.1 General

It may be necessary to support or surround pipe sewers or drains by means of concrete in certain circumstances. Some of the suggested methods are given in 5.6.4.2 to 5.6.4.4.

5D.5.6.4.2 Bedding

Bedding (*see* Fig. 20) shall be rectangular in section and shall extend laterally at least 6 inches beyond and on both sides of the projection of the barrel of the pipe. The thickness of the concrete below the barrel of the pipe shall be not less than 4 inches for pipes under 6 inches diameter and 6 inches for pipes 6 inches and over in diameter. Where bedding is used alone, the concrete shall be brought up at least to the invert level of the pipe to form a cradle and to avoid line contact between the pipe and the bed.

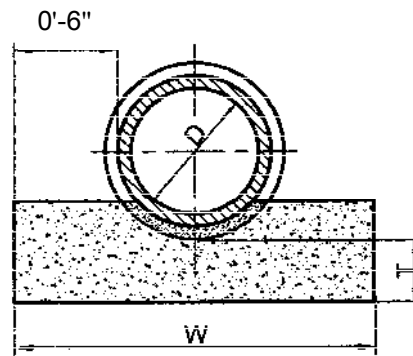

$$W = D + 1'-0''$$

where D is external diameter of the pipe

T = 4" for pipes under 6" nominal dia (or) 6" for pipes of 6" nominal dia and over

Fig. 5d.20 Bedding

5D.5.6.4.3 Hunching

Concrete hunching (see Fig. 21) shall consist of:

- a) A concrete bed as described for bedding (see Fig- 5.6.4.2);
- b) The full width of the bed carried up to the level of the horizontal diameter of the pipe; and
- c) Splays from this level carried up on both sides of the pipe, from the full width of the bed to meet the pipe barrel tangentially.

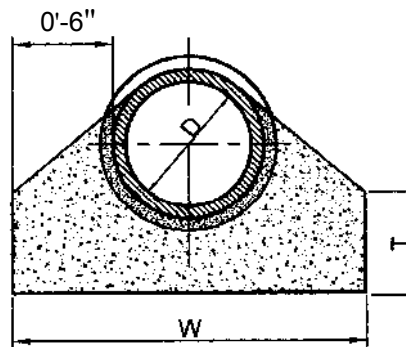

$$W = D + 1'-0''$$

where D is external diameter of the pipe

T = 4" for pipes under 6" nominal dia (or) 6" for pipes of 6" nominal dia and over

Fig. 5d.20 Haunching

5D.5.6.4.4 Surround or Encasing

The surround or encasing (see Fig. 22) shall be similar to hunching up to the horizontal diameter of the pipe and the top portion over this shall be finished in a semicircular form to give a uniform encasing for the top half of the pipe.

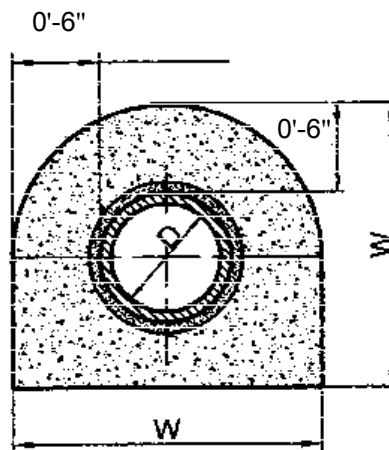

$$W = D + 1'-0''$$

where D is external diameter of the pipe

Fig. 5d.20 Surround Or Encasing

5D.5.6.5 Connection to Existing Sewers

The connection to an existing sewer shall, as far as possible, be done at the *manholes*. *Where it is* unavoidable to make connection in between two manholes, the work of breaking into the existing sewer and forming the connection shall be carried out by the Authority or under its supervision.

5D.5.6.5.1

Breaking into the sewer shall be effected by the cautious enlargement of a small hole and every precaution shall be taken to prevent any material from entering the sewer. No connection shall be formed in such a way as to constitute a projection into the sewer or to cause any diminution in its effective size.

5D.5.6.6 Back-Filling

5D.5.6.6.1

Filling of the trench shall not be commenced until the length of pipes therein has been tested and passed (*see* 5.10.2).

5D.5.6.6.2

All timber which may be withdrawn with safety shall be removed as filling proceeds.

5D.5.6.6.3

Where the pipes are unprotected by concrete haunching, the first operation in filling shall be carefully done to hand-pack and tamp selected fine material around the lower half of the pipes so as to buttress them to the sides of the trench.

5D.5.6.6.4

The filling shall then be continued to 6 inches over the top of the pipe using selected fine hand-packed material, watered and rammed on both sides of the pipe with a wooden rammer. On no account shall material be tipped into the trench until the first 6 inches of

filling has been completed. The process of filling and tamping shall proceed evenly so as to maintain an equal pressure on both sides of the pipeline.

5D.5.6.6.5

Filling shall be continued in layers not exceeding 6 inches in thickness, each layer being watered and well rammed.

5D.5.6.6.6

In roads, surface materials previously excavated shall be replaced as the top layer of the filling, consolidated and maintained satisfactorily till the permanent reinstatement of the surface is made by the Authority.

5D.5.6.6.7

In gardens, the top soil and turf, if any, shall be carefully replaced.

5D.5.7 Construction Relating to Conveyance of Rain or Storm Water**5D.5.7.1 Roof Gutters**

Roof gutters shall be of any material of suitable thickness. All junctions and joints shall be water-tight.

5D.5.7.2 Rain-Water Pipes

Rain water pipes shall conform to the accepted standards [9-1(32)].

5D.5.7.3 Sub-soil Drain Pipes**5D.5.7.3.1 Field drain pipes**

Suitable pipes for this purpose are plain cylindrical glazed water pipes, or concrete porous pipes though the latter may prove unsuitable where sub-soil water carries sulphates or is acidic. Trenches for these pipes need be just wide enough at the bottom to permit laying the pipes, which shall be laid with open joints to proper lines and gradients.

It is advisable to cover the pipes with clinker free from fine ash, brick ballast or other suitable rubble, or a layer of inverted turf, brush-wood or straw before refilling the trench, in order to prevent the infiltration of silt through the open joints. Where the sub-soil drain is also to serve the purpose of collecting surface water, the rubble shall be carried up to a suitable level and when required for a lawn or playing field, the remainder of the trench shall be filled with pervious top soil. When refilling the trenches, care shall be taken to prevent displacement of pipes in line of levels. When they pass near trees or through hedges, socket pipes with cement or bitumen joints shall be used to prevent penetration by roots.

5D.5.7.3.2 French Drain

A shallow trench is excavated, the bottom neatly trimmed to the gradient and the trench filled with broken stone, gravel or clinker, coarse at the bottom and finer towards the top.

5D.5.8 Selection and Installation of Sanitary Appliances**5D.5.8.1**

Selection, installation and maintenance of sanitary appliances shall be done in accordance with good practice [9-1(33)].

5D.5.9 Refuse Chute System

5D.5.9.1

Refuse chute system is provided in multi- storeyed buildings for transporting and collecting in a sanitary way the refuse from floors at different heights. The refuse is received from the successive floor through the inlets located on the vertical system of pipes that convey refuse through it and discharge it into the collecting chamber from where the refuse is cleared at suitable intervals.

5D.5.9.2

This system has got three functionally important components, namely, the chutes, the inlet hopper and the collection chamber.

5D.5.9.2.1

The chute may be carried through service shafts meant for carrying drainage pipes. However, the location shall be mostly determined by the position of the inlet hopper and the collecting chamber that is most convenient for the user. It should also be considered to locate the chute away from living rooms in order to avoid noise and smell nuisance.

5D.5.9.2.2

In individual chute system, the inlet hopper shall be located in the passage near the kitchen and in the common chute system towards the end of the common passage. Natural ventilation should be adequate to prevent any possible odour nuisance. There should be adequate lighting at this location. For ground floor (floor 1), the inlet hopper may be placed at a higher level and a flight of steps may be provided for using the same.

5D.5.9.2.3

The collection chamber shall be situated at ground level.

5D.5.9.2.4

Requirements in regard to the design and construction of refuse chute system shall be in accordance with good practice [9-1(34)].

5D.5.10 Inspection and Testing

5D.5.10.1 Inspection

5D.5.10.1.1

All sanitary appliances and fitments shall be carefully examined for defects before they are installed and also on the completion of the work.

5D.5.10.1.2

Pipes are liable to get damaged in transit and, notwithstanding tests that may have been made before despatch, each pipe shall be carefully examined on arrival on the site. Preferably, each pipe shall be rung with a hammer or mallet and those that do not ring true and clear shall be rejected. Sound pipes shall be carefully stored to prevent damage. Any defective pipes shall be segregated, marked in a conspicuous manner and their use in the works prevented.

5D.5.10.1.3

Cast iron pipes shall be carefully examined for damage to the protective coating. Minor damage shall be made good by painting over with hot tar or preferably bitumen. But if

major defects in coating exit, the pipes shall not be used unless recoated. Each pipe shall be carefully re-examined for soundness before laying.

5D.5.10.1.4

Close inspection shall be maintained at every stage in the work, particularly as to the adequacy of timber supports used in excavation and the care and thoroughness exercised in filling.

5D.5.10.1.4.1

Careful note shall be kept of the condition of any sewer, manhole or other existing work which may be uncovered and any defects evident shall be pointed out immediately to the Authority.

5D.5.10.1.4.2

No work shall be covered over or surrounded with concrete until it has been inspected and approved by the Authority.

5D.5.10.2 Testing

5D.5.10.2.1

Comprehensive tests of all appliances shall be made by simulating conditions of use. Overflow shall be examined for obstructions.

5D.5.10.2.2 Smoke test

All soil pipes, waste pipes, and vent pipes and all other pipes when above ground shall be approved gas-tight by a smoke test conducted under a pressure of 1 inch of water and maintained for 15 min after all trap seals have been filled with water. The smoke is produced by burning only waste or tar paper or similar material in the combustion chamber of a smoke machine. Chemical smokes are not satisfactory.

5D.5.10.2.3 Watertest

5D.5.10.2.3.1 For pipes other than cast iron

Glazed and concrete pipes shall be subjected to a test pressure of at least 5 ft head of water at the highest point of the section under test. The tolerance figure of 8 gallons / inches of diameter/mile may be allowed during a period of 10 min. The test shall be carried out by suitably plugging the low end of the drain and the ends of connections, if any, and filling the system with water. A knuckle bend shall be temporarily jointed in at the top end and a sufficient length of the vertical pipe jointed to it so as to provide the required test head, or the top end may be plugged with a connection to a hose ending in a funnel which could be raised or lowered till the required head is obtained and fixed suitably for observation.

Subsidence of the test water may be due to one or more of the following causes:

- absorption by pipes and joints;
- sweating of pipes or joints;
- leakage at joints or from defective pipes; and
- trapped air.

Allowance shall be made for (a) by adding water until absorption has ceased after which the test proper should commence. Any leakage will be visible and the defective

part of the work should be cut out and made good. A slight amount of sweating which is uniform may be overlooked, but excessive sweating from a particular pipe or joint shall be watched for and taken as indicating a defect to be made good. A slight amount of sweating which is uniform may be overlooked, but excessive sweating from a particular pipe or joint shall be watched for and taken as indicating a defect to be made good.

NOTE — This test will not be applicable to sanitary pipe work above ground level.

5D.5.10.2.3.2 For cast iron pipes

Cast iron sewers and drains shall be tested as for glazed and concrete pipes. The drain plug shall be suitably strutted to prevent their being forced out of the pipe during the test.

5D.5.10.2.4 Tests for straightness and obstruction

The following tests shall be carried out:

- a) by inserting at the high end of the sewer or drain a smooth ball of a diameter $\frac{1}{2}$ inch less than the pipe bore. In the absence of obstruction, such as yarn or mortar projecting through the joints, the ball should roll down the invert of the pipe, and emerge at the lower end; and
- b) by means of a mirror at one end of the line and lamp at the other. If the pipeline is straight, the full circle of light may be observed. If the pipe line is not straight, this will be apparent. The mirror will also indicate obstruction in the barrel.

5D.5.10.2.5 Test records

Complete records shall be kept of all tests carried out on sewers and drains both during construction and after being put into service.

5D.5.11 Maintenance

5D.5.11.1 General

Domestic drainage system shall be inspected at regular intervals. The system shall be thoroughly cleaned out at the same time and any defects discovered shall be made good.

5D.5.11.2 Cleaning of Drainage System

5D.5.11.2.1

Sewer maintenance crews, when entering a deep manhole or sewer where dangerous gas or oxygen deficiencies may be present, shall follow the following procedures:

- a) Allow no smoking or open flames and guard against sparks.
- b) Erect warning signs.
- c) Use only safety gas-proof, electric lighting equipment.
- d) Test the atmosphere for noxious gases and oxygen deficiencies (presence of hydrogen sulphide is detected using lead acetate paper and that of oxygen by safety lamps).
- e) If the atmosphere is normal, workmen may enter with a safety belt attached and with two men available at the top. For extended jobs, the gas tests shall be repeated at frequent intervals, depending on circumstances.

- f) If oxygen deficiency or noxious gas is found, the structure shall be ventilated with pure air by keeping open at least one manhole cover each on upstream and downstream side for quick exit of toxic gases or by artificial means. The gas tests shall be repeated and the atmosphere cleared before entering. Adequate ventilation shall be maintained during this work and the tests repeated frequently.
- g) If the gas or oxygen deficiency is present and it is not practicable to ventilate adequately before workers enter, a hose mask shall be worn and extreme care taken to avoid all sources of ignition. Workers shall be taught how to use the hose equipment. In these cases, they shall always use permissible safety lights (not ordinary flash lights), rubber boots or non-sparking shoes and non-sparking tools;
- h) Workmen descending a manhole shaft to inspect or clean sewers shall try each ladder step or rung carefully before putting the full weight on it to guard against insecure fastening due to corrosion of the rung at the manhole wall. When work is going on in deep sewers, at least two men shall be available for lifting workers from the manhole in the event of serious injury; and
- i) Portable air blowers, for ventilating manhole, are recommended for all tank, pit or manhole work where there is a question as to the presence of noxious gas, vapours or oxygen deficiency. The motors for these shall be of weather proof and flame-proof types; compression ignition diesel type (without sparking plug) may be used. When used, these shall be placed not less than 6 feet 6 inches away from the opening and on the leeward side protected from wind, so that they will not serve as a source of ignition for any inflammable gas which might be present. Provision should be made for ventilation and it should be of the forced type which can be provided by a blower located at ground level with suitable flexible ducting to displace out air from the manhole.

5D. 5.11.2.2

The following operations shall be carried out during periodical cleaning of a drainage system.

- a) The covers of inspection chambers and manholes shall be removed and the side benching and channels scrubbed;
- b) The interceptive trap, if fitted, shall be adequately cleaned and flushed with clean water. Care shall be taken to see that the stopper in the rodding arm is securely replaced;
- c) All lengths of main and branch drains shall be rodded by means of drain rods and a suitable rubber or leather plunger. After rodding, the drains shall be thoroughly flushed with clean water. Any obstruction found shall be removed with suitable drain cleaning tools and the system thereafter shall be flushed with clean water;
- d) The covers of access plates to all gullies shall be removed and the traps plunged and flushed out thoroughly with clean water. Care shall be taken not to flush the gully deposit into the system;
- e) Any defects revealed as a result of inspection or test shall be made good;
- f) The covers or inspection chambers and gullies shall be replaced, bedding them in suitable grease or other materials; and

- g) Painting of ladders/rings in deep manholes and external painting of manhole covers shall be done with approved paints.
- h) In the case of WWTP built under the floor slab, it must have at least 2 feet space around the perimeter of the tank to enable regular inspection and maintenance. It must have at least 3 feet vertical space between the floor slab and cover slab of the tank to enable regular inspection and maintenance.

5D.5.11.3

All surface water drains shall be periodically rodded by means of drain rods and a suitable rubber or leather plunger. After rodding, they shall be thoroughly flushed with clean water. Any obstruction found shall be removed with suitable drain cleaning tools.

5D.5.11.4

All sub-soil drains shall be periodically examined for obstruction at the open joints due to the roots of plants or other growths.

5D.6 SOLID WASTE MANAGEMENT

5D.6.1 General

5D.6.1.1

Efficient collection and disposal of domestic garbage from a building or activity area is of significant importance to public health and environmental sanitation and, therefore, an essential part of the construction of the built environment. Notwithstanding the provisions given herein, the solid waste management shall have to comply with relevant statutory Rules and Regulations in force from time- to-time. In this regard, the provisions of the following shall govern the procedures for handling, treatment, etc of solid wastes as applicable to the concerned building occupancy:

- a) Manufacture, Storage and Import of Hazardous Chemical Rules, 1989;
- b) Bio-Medical Waste (Management and Handling Rules, 1998; and
- c) Municipal Solid Wastes (Management and Handling) Rules, 2000.

5D.6.1.2

The provisions relating to solid waste management given in 6.2 are applicable to wastes in general, and specifically exclude the hazardous chemical wastes and bio-medical waste.

5D.6.2 Solid Waste Management Systems

5D.6.2.1

In designing a system dealing with collection of domestic garbage for a built premises/community/ environment, the aim shall be to provide speedy and efficient conveyance as an essential objective for design of the system. The various available systems may be employed in accordance with 6.2.1 to 6.2.3, which may be adopted individually or in combination as appropriate in specific situations.

5D.6.2.2 Refuse Chute System

5D.6.2.2.1

Refuse chute system is a convenient and safe mode of collection of domestic solid wastes from buildings exceeding 3 storeys. The internal diameter of the chute shall be at least 1 ft.

The access to the refuse chute shall be provided from well ventilated and well illuminated common corridor or lobby and preferably it should not be located opposite or adjacent to entry of individual flats or lift.

5D.6.2.2.2 Opening for feeding of refuse chute

Opening, with top or bottom hinged shutters with appropriate lockable latch, shall be provided for convenient accessing of the refuse chute by users.

5D.6.2.2.3 Refuse collection chamber

The collection chamber may be located in ground floor or basement level, provided appropriate arrangement is made for (a) drainage of the collection pit by gravity flow to ensure its dryness, (b) an appropriate ramp access is provided for convenient removal of garbage from the collection pit, and (c) satisfactory ventilation for escape of gas and odour. The floor of the chamber shall be provided with drainage through a 4 inches diameter trap and screen to prevent any solid matters flowing into the drain and the drain shall be connected to the sewer line. The floor shall be finished with smooth hard surface for convenient cleaning.

The height of the collection chamber and vertical clearance under the bottom level of garbage chute shall be such that the garbage trolley can be conveniently placed.

The collection chamber shall be provided with appropriate shutter to prevent access of all scavenging animals like the cattle, dogs, cats, rats, etc.

5D.6.2.2.4 Material for chute

The chute may be of masonry or suitable non-corrosive material. Further the material should be rigid with smooth internal finish, high ductility and alkali/acid resistant properties.

5D.6.2.2.5 Size of trolley

The size of the garbage trolley shall be adequate for the daily quantity of garbage from a chute. For working out quantity of garbage, a standard of approximately 0.75 kg/person may be taken.

5D.6.2.3 Dumb-Waiter

In high rise buildings with more than 8 storeys, electrically operated dumb-waiters may be used for carrying domestic garbage in packets or closed containers. For handling of garbage by dumb-waiters in a building, a garbage chamber shall have to provided either at ground floor or basement level and the provisions of garbage collection chamber for chute as given in 6.2.2 shall apply.

5D.6.2.3.1 Shutters for dumb-waiter

The shutters for dumb-waiter and garbage collection chamber shall be provided with shutters with same consideration as in the case of garbage chute. However, the dumb-waiter shall be made child-proof.

5D.6.2.3.2 Sorting of garbage to remove toxic matters from garbage

Before feeding the garbage to compost pits the following objects need to be removed:

- a) inert matters like glass, metals, etc chemicals, medicines, batteries of any kind;
- b) polythene and plastic materials; and

- c) any other non-biodegradable material.

These separated items shall be handled separately, and may be scrapped or recycled, etc as appropriate.

5D.6.2.4

Bin center system is a simple, convenient, safe, affordable and sustainable mode of collection of domestic waste from buildings regardless of storeys. Preferably it should be located at the back and side of the building provided that the bins are accessible for removal of garbage.

5D.6.2.4.1

The size should be adequate to store two days quantity of garbage volume. A standard of approximately 1.65 lb / person may be taken.

5D.6.2.4.2

The structure may be built of RCC, brick work or any other non-porous material. The structure should be water tight and well ventilated. It must be covered with hinged shutter for convenience accessing to the user.

5D.6.3 Garbage Collection system

Location

5D. 6.3.1 Garbage Chute System (GCS)

5D.6.3.1.1

Garbage Chute System is a convenient and safe means of collection of domestic joined wastes (Garbage) from high rise building when properly designed, constructed, operated and maintained.

5D.6.3.1.2

The access to the garbage chute shall be provided from a well ventilated and well illuminated common corridor.

5D.6.3.1.3

It should not be located opposite or/and adjacent to entry of individual apartments or lifts.

Construction

5D. 6.3.2

Free standing garbage chute may be used. The chute must rise vertically through the building up to the roof level and properly vented.

5D.6.3.2.1

The chute must be provided with close-fitting access hopper at every floor.

5D.6.3.2.2

For reducing the risk of blockage in the chute, the diameter of the chute should not be less than 2 feet.

5D.6.3.2.3

The diameter of the vent pipe should not be less than 9 inches.

5D.6.3.2.4

The chute is required to have smooth, non-absorbent, non-combustible surfaces and non-crackable surfaces the chute may be constructed of glazed fireclay, masonry or concrete pipes.

5D.6.3.3 Occupants using chute**5D.6.3.3.1**

Occupants should have not more than 30 m to walk to the point of access to the chute. For reasons of hygiene and maintenance, more than 6 dwellings/apartments should not share one access hopper.

5D.6.3.4 Garbage handling**5D.6.3.4.1**

Wastes shall be collected and securely wrapped in 'garbage bags' when discarding it through the access hopper into the chute, and down into the container located at the lowest end of the chute at ground level.

5D.6.3.5 Container / Garbage Trolley**5D.6.3.5.1**

The container is housed in a garbage collecting chamber with proper shutter to prevent all scavenging animals like dogs, rodents, flies and rats etc. from gaining access to the chamber. The floor of the chamber shall be properly drained.

5D.6.3.5.2

It is preferable that the container is fitted with appropriate wheels, as a trolley, for easy maneuver to and from the collection chamber by the garbage handlers.

5D.6.3.5.3

The size of the container/garbage trolley shall be adequate for the daily quantity of garbage generated from the apartments it serves.

A minimum of 2 containers/ garbage trolleys would be adequate for storing garbage from the chute for at least one day.

5D.6.4 Service lift handling system**5D.6.4.1**

In this case a service lift is provided for the occupants to use the lift for transporting the daily garbage to the bin center located at ground level.

Note: All wastes should be securely wrapped in garbage bags.

5D.6.4.2 The following should be noted and due consideration given;

- a) Provision of garbage bin centre.
- b) Disposal of garbage from the premises.
- c) Proper maintenance of garbage bin in healthy environment condition.